

EBS-6600/EBS-6900

BOLTMARK® II-SERIES

BASIC OPERATING INSTRUCTIONS



VERSION: 2018/02/27#2.0EN

Dear User,

*This version of the document includes most of the modifications implemented to the **EBS Ink Jet Systeme** printers up to software version **37_1A**, and the descriptions contained therein correspond to the printers on which this software version is installed.*

*The product delivered to you corresponds to your specific order, and it may happen that the options and functionality of your printing system differ from some descriptions or illustrations. As we need to keep pace with new technological advancement and wish to meet individual requirements of our clients, we reserve the right to introduce changes in the design and construction as and when necessary. Therefore, claims cannot be made regarding differences to data, illustrations or descriptions contained in this manual. Should your printer be equipped with options or software that are not illustrated or described in this manual or should you have additional queries after having read the manual, please contact any **EBS Ink Jet Systeme** authorized representative office for more information.*

The manufacturer shall not be liable for any damages to the printer resulting from the failure to follow the instructions or from consequences of editorial or publishing errors contained in this manual.

The application and use of the products are beyond our control and are under full responsibility of the user.

This document has originally been drawn up in English. Any other language versions are translations from the original version. Should any discrepancies occur, the English language version shall prevail.

This manual applies to the following **BOLTMARK® II-series** printers:

- **EBS-6600 BOLTMARK® II**; a low investment printer designed for simple applications,
- **EBS-6900 BOLTMARK® II**; an all-round printer on which the full range of options can be installed.

This document contains only basic information on the **BOLTMARK® II-series** printer to enable a user to:

- start up/shut down the printer,
- create/edit a text,
- select a text for printing,
- start/pause printing,
- replace bottles (of ink and solvent),
- keep the printhead clean.

For full information about printer equipment, installation, configuration and operation see *The BOLTMARK® II-series Printers User Manual*.

● RESPONSIBILITY

EBS Ink Jet Systeme shall not be responsible for damage or personal injuries that might occur during installation, operation or maintenance of the **EBS Ink Jet Systeme** printers due to the failure to follow the safety instructions and also the good manufacturing practices and safety standards generally established in the industry.

Every user who modifies or repairs the **EBS Ink Jet Systeme** printers using consumables, spare parts or accessories other than those supplied by **EBS Ink Jet Systeme** or inconsistent with the **EBS Ink Jet Systeme** specifications, does that on his/her own responsibility and therefore shall not be entitled to make claims under the warranty given to him/her.

EBS Ink Jet Systeme shall not be responsible for any failures or damage caused by modifications to the printer or by the application of the printer to other purposes than those the printer is designed for. The user shall be responsible for ensuring that any required precautions are taken each time the **EBS Ink Jet Systeme** printer is used.



The **EBS Ink Jet Systeme** consumables, spare parts and accessories are designed for use in the **EBS Ink Jet Systeme** printers. The application of consumables, spare parts and accessories not manufactured or recommended by **EBS Ink Jet Systeme** for use with a particular printer may cause printer malfunction or lead to printer damage, and it always results in loss of the right to warranty claims.

The **EBS Ink Jet Systeme** printers are tested together with **EBS Ink Jet Systeme** consumables and spare parts according to the relevant safety regulations and standards, therefore any use of consumables and spare parts other than those supplied by **EBS Ink Jet Systeme** may distort the test conditions and affect the conformity of the printer with certain standards, as well as it may impair specified parameters, properties or performances of the printer. The user shall bear all risks involved with the use of improper consumables and spare parts.

● SAFETY RULES

No efforts have been spared to design the printer diligently so that its operation is safe and reliable. However, the knowledge and observance of a few safety rules and precautions are the prerequisite for safe use of the printer.

- Before using the **BOLTMARK® II-series** printer read carefully the consumable data sheets.
- Every service operation must be performed exclusively by the manufacturer's authorized service staff or by a user who has been trained by the manufacturer's authorized representatives in performing such operations. This shall also apply to:
 - installation and removal of the printer,
 - the operations that involve opening or taking off any protective shields different than printhead cover and consumables compartment door. An untrained user can remove printhead cover exclusively when the printer is disconnected from the electric mains.

- A printer user can enjoy **OPERATOR**  and **ADVANCED OPERATOR**  privileges. The **SERVICEMAN**  access level, which offers access to all service procedures, is designed exclusively for the manufacturer's authorized service staff.
- The printer should be operated by trained personnel. It is recommended that the printer be supervised during operation.
- Do not print on objects whose temperature exceeds **100°C (212°F)** at the time of labeling.
- Make any manipulations in the electrical part of the printer only when the power is turned off.
- Never direct the printhead outlet towards persons or animals. Even if the printer is shut down.
- Wear protective clothing and goggles while performing any operations in the ink system and the printhead.
- While an iModule® and bottles are being installed/replaced in the consumables compartment be careful not to get wounded with the needles that are part of their connectors.
- Do not use plastic vessels for washing. Drip pans of metal are recommended.
- If you need to disconnect the printer from the electrical mains, take out power plug from the mains or set main power switch **POWER** to the "O" position.
- Do not use the printer if it is not fully operational.

● IN CASE OF ACCIDENT

When ink spills, wipe the spilled liquid with absorbent material and dispose of it following the fire and health and safety at work regulations.

Take the splashed clothes off as soon as possible.

If eyes or skin get irritated:

- **EYES** need rinsing with running water over 15 minutes; then contact an ophthalmologist,
- **SKIN** needs washing with water and soap.

● FIRE PROTECTION

The instructions described in the data sheets for every ink or solvent should be followed strictly.

- Place a fire extinguisher (designed for extinguishing electrical equipment and flammable solvent fires) near the printer.
- Do not print in the areas where an explosion hazard exists.
- Do not use open flames or sparking devices in the printer work area.
- Do not leave ink, solvent or wash-up in open containers.
- Before coming close to flammable liquids touch a grounded metal object (e.g. the grounded printer housing).
- Ensure good ventilation in the area where the printer is installed (especially near the print-head) and where consumables are stored.

● WORKING CONDITIONS

- Connect the printer to an electric outlet equipped with protective grounding.
- Supply voltage: **100 - 240 VAC, 50/60 Hz.**
- Working temperature:
 - +5 - +40 °C (+41 - +104 °F) for static operation.
 - +15 - +40 °C (+59 - +104 °F) for dynamic operation.
- Relative humidity: **up to 90%** without condensation.
- Connect the protective pin of the printer to a grounded element of the industrial plant, e.g. to a belt conveyor. This is required especially when the printer is connected to a telecommunications network.
- Discharge vapors via an unobstructed pipe to the outside of the building.
- Ensure free access to the printer, especially to the main power switch **POWER** which is a safety switch.
- Put the printer in a horizontal position on an **EBS Ink Jet Systeme** table or stand or hang it on a rack; the printer should be protected against movement.
- Put the photodetector and the printhead in a convenient place to label objects comfortably; the printhead should be situated in a place where no shock or vibration occurs.
- The printer is equipped with a built-in, non-replaceable lit-manganese battery. The battery must not be removed, replaced, crushed, punched, thrown into water or fire.

● COMPLIANCE WITH STANDARDS

The manufacturer declares with its full responsibility that when installed and operated in compliance with the manufacturer's instructions, the **BOLTMARK® II-series** printers together with their manufacturer-supplied accessories meet the essential requirements and other relevant provisions of the following European Union Directives:

- 1999/5/EC,
- 2011/65/UE

and meet the following harmonized standards:

Standard	RED Directive reference
<ul style="list-style-type: none"> ● EN 60950-1:2006 + A11:2009 + A1:2010 + A12:2011 + A2:2013, ● EN 50364:2010, 	The user and other persons' health and safety requirements - with reference to Art. 3, par. 1 a)
<ul style="list-style-type: none"> ● ETSI EN 301 489-1 V1.9.2, ● ETSI EN 301 489-3 V1.6.1, ● EN 61000-6-4:2007 + A1:2011, ● EN 61000-6-2:2005 + AC:2005, 	The protection requirements with respect to electromagnetic compatibility - with reference to Art. 3, par. 1 b)
<ul style="list-style-type: none"> ● ETSI EN 300 330-1 V1.8.1, ● ETSI EN 300 330-2 V1.6.1. 	Effective use of the spectrum allocated to radio communication - with reference to Art. 3, par. 2

Therefore the **BOLTMARK® II-series** printers bear the mark:

CE 1471*

* - the number of the notified body involved in the conformity assessment procedure.



The full EC Declaration of Conformity is available at a client's request from authorized distributors.

The **BOLTMARK® II-series** printers are class **A** equipment as defined by **EN 55022:2010 + AC:2011** (industrial environment). In a domestic environment they may cause radio interference in which case the user may be required to take adequate counter measures.



The printer should be installed for the first time by the distributor's authorized serviceman.

A trained user can reinstall/move the printer to another workplace provided that the printer:

- is filled with ink,
- has previously been prepared for transporting in compliance with the instructions given in *The BOLTMARK® II-series Printers User Manual* or has been supplied without iModule®, and a new iModule® unit (or the one used in that printer before) has been delivered separately.

Recommended modes of installation

- installing on a **CIJ** printer stand,
- installing on a hanger,
- installing on a firm table.

Place the printer in a convenient place to ensure easy access to:

- operator panel,
- accessories connector plate, including main power switch **POWER**, which is a safety cut-off switch,
- the consumables chamber

Discharge vapors to the outside of the building.

Secure the printer and other elements of the printing system against movement.

Connect the protective pin of the printer to a grounded element of the industrial plant.

Install the printhead in a place that:

- ensures convenient access to objects to be labeled,
- is free from shocks and vibration,
- makes contact of the head cable with another object impossible.

The printhead can print in **any** position.

The minimum head cable bend radius is:

- **75 mm** for static operation,
- **150 mm** for dynamic operation.

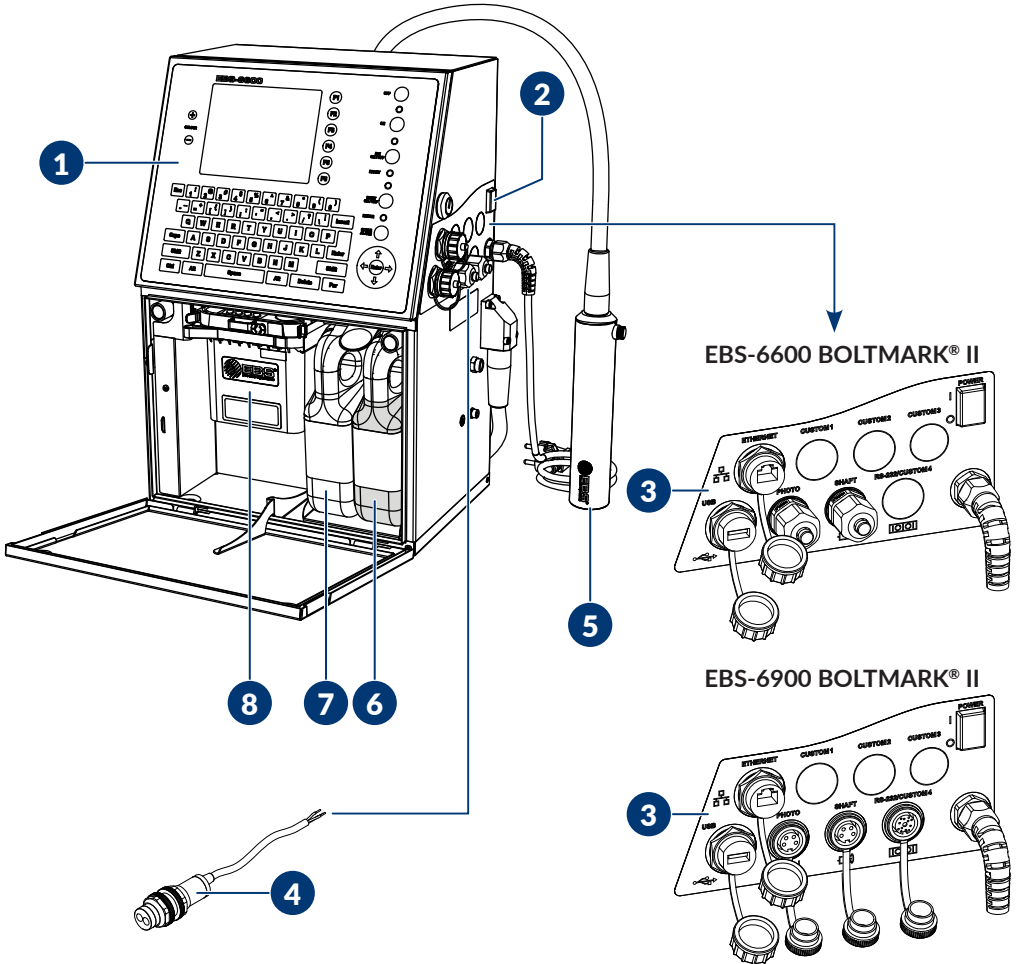

1. Operator panel.
2. Power switch **POWER**; a safety cut-off switch.
3. Accessories connector plate.
4. Photodetector.
5. Printhead.
6. Ink bottle (with a black cap).
7. Solvent bottle (with a white cap).
8. iModule®.

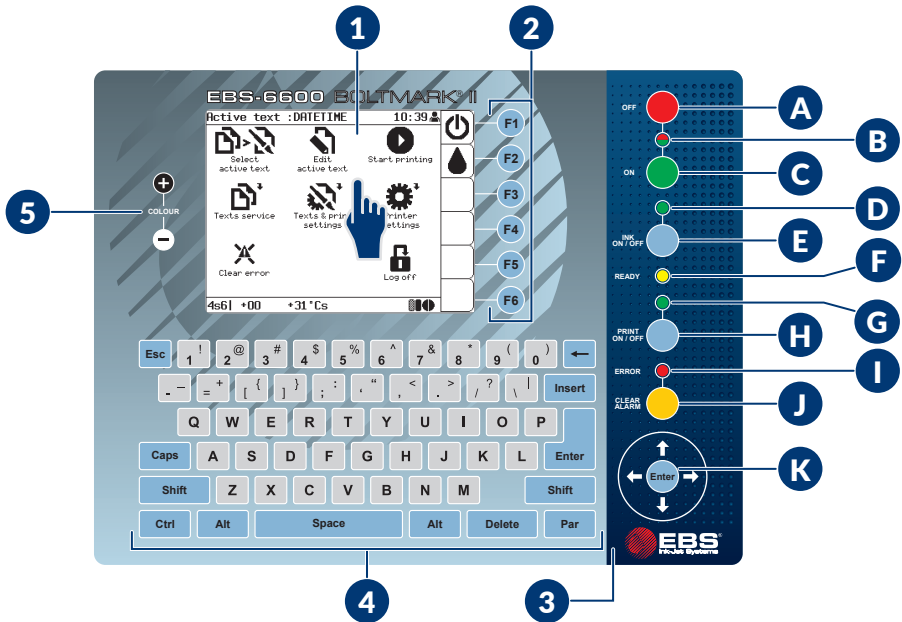

1. LCD touch screen.
2. Function buttons.
3. Main panel.
 - A. Printer shutdown button.
 - B. LED indicator of printer state: on (🌿), off (🌸).
 - C. Printer startup button.
 - D. LED indicator of ink flow in the printhead: flow started (🌿), flow in the process of being started/stopped (🌱).
 - E. Button for starting/stopping ink flow in the printhead.
 - F. LED indicator of readiness of the printer for printing.
 - G. LED indicator of printing state.
 - H. Button for starting/pausing printing.
 - I. LED indicator of alarm state.
 - J. Button for clearing an alarm.
 - K. Navigation buttons.
4. Alphanumeric keyboard.
5. LCD color change buttons.

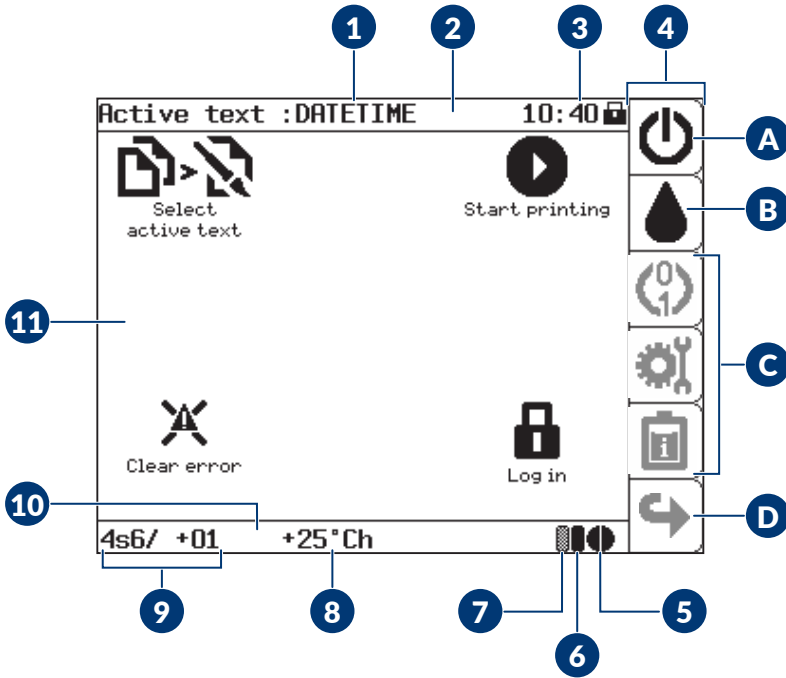

1. Name of the active or printed text.
2. Information bar.
3. Current time and the icon of the currently logged in user.
4. Function identification icons bar.
 - A. Printer shutdown icon.
 - B. Icon for starting/stopping Ink flow in the printhead.
 - C. User shortcut icons - unavailable to **OPERATOR** .
 - D. Navigation icon - unavailable to **OPERATOR** .
5. iModule® consumption/wear indicator.
6. Ink level indicator.
7. Solvent level indicator.
8. Power supply (s) and printhead (h) temperatures.
9. Printhead status.
10. Printer status bar.
11. User Interface working window.

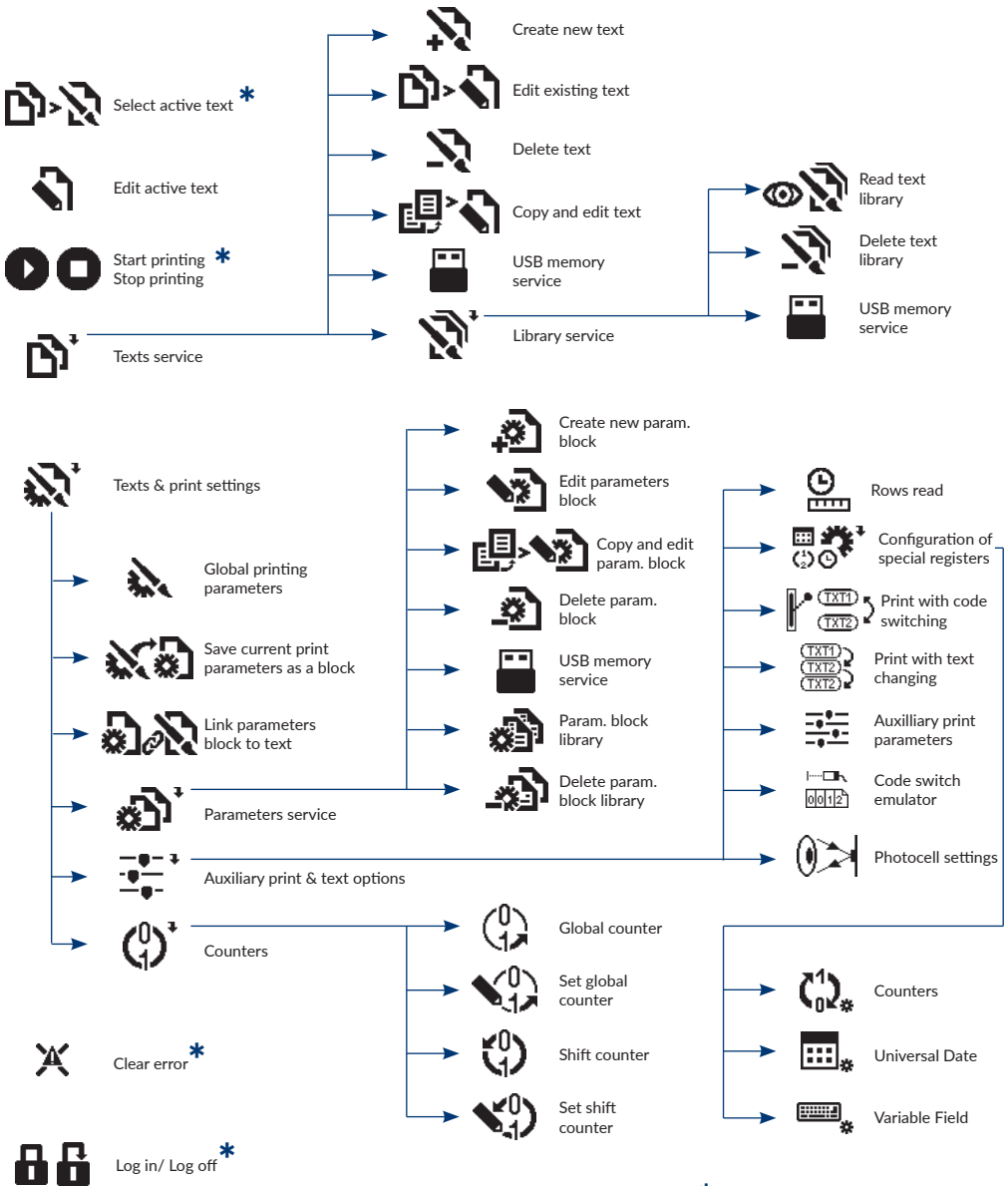

* available to OPERATOR 

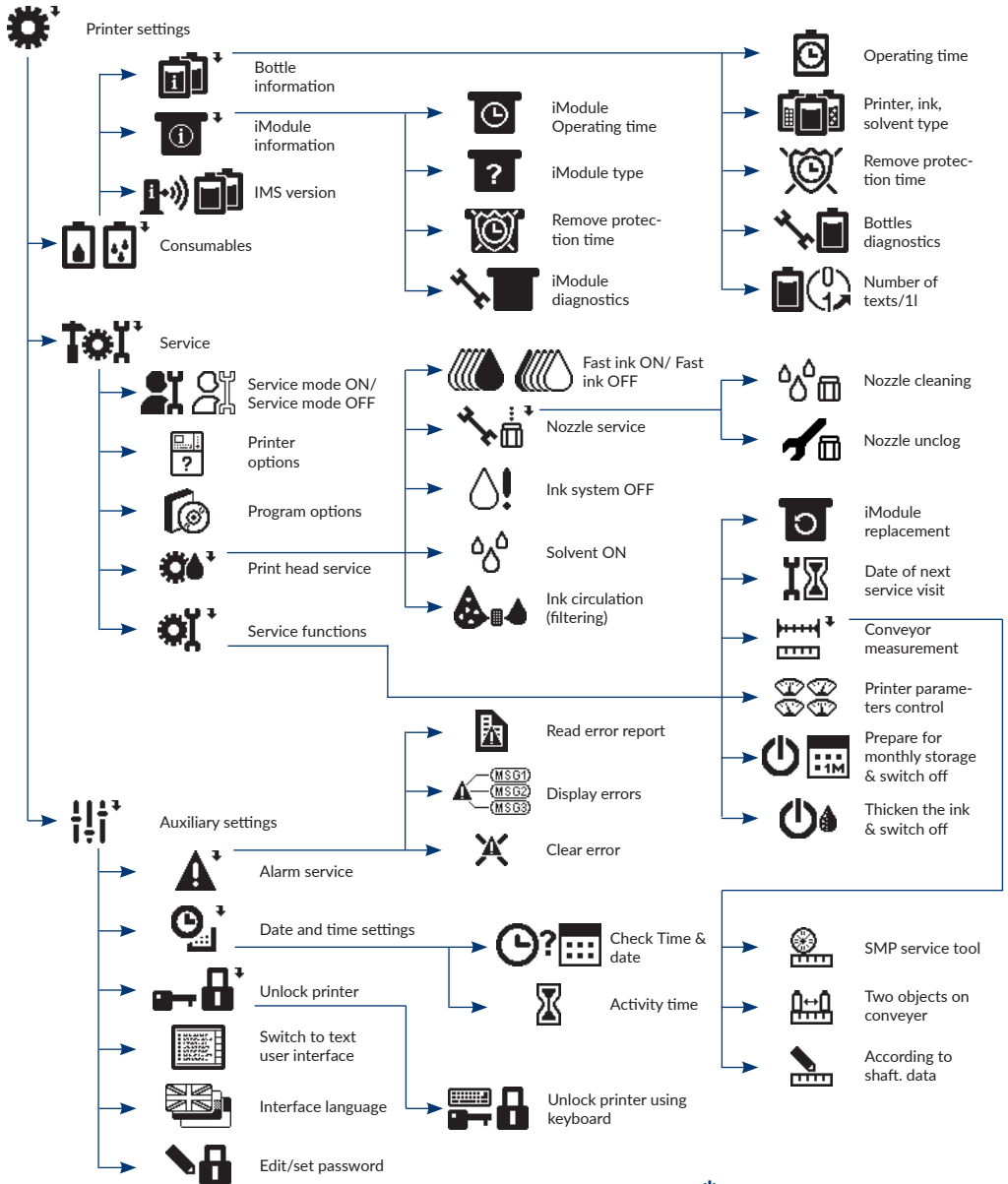

* available to OPERATOR

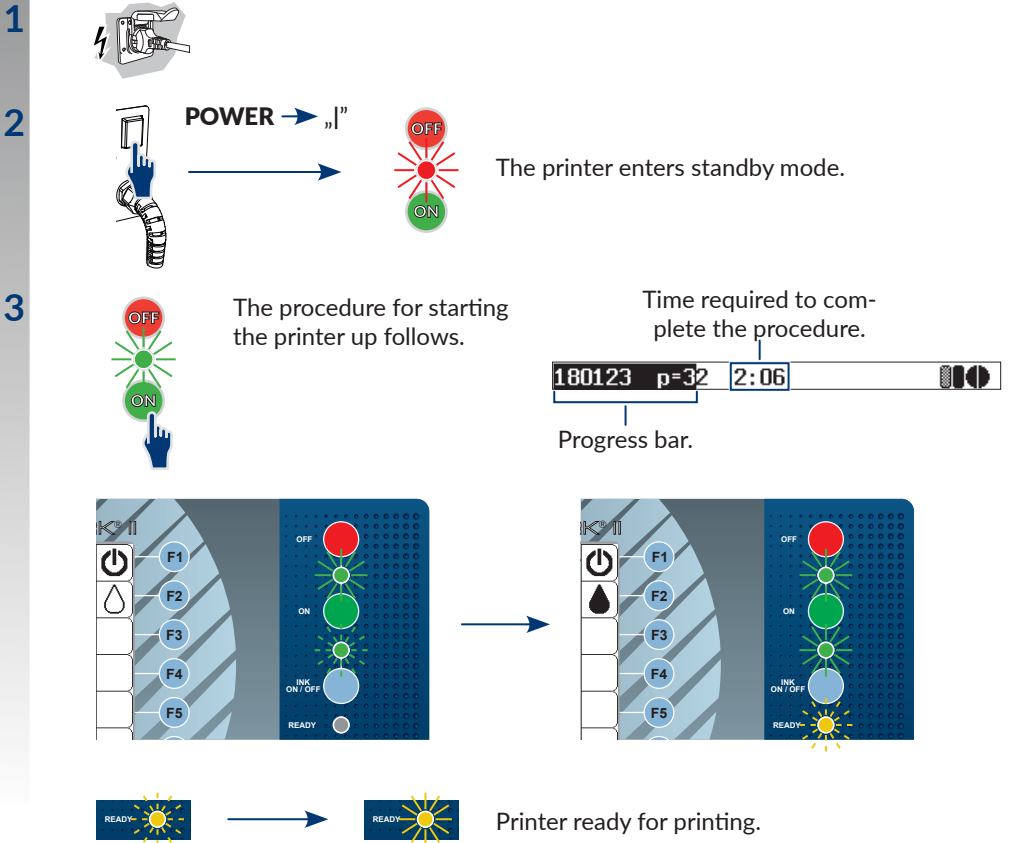

When the startup procedure is followed, the iModule® transport protection must be open. An attempt to start up the printer when the transport protection is closed, results in the following message

VACUUM DOESN'T INCREASE, Check iModule transport protection and turn ink on

In such a case clear the alarm with the  button, open the iModule® transport protection and start ink flow in the printhead by pressing the  icon in the function identification icon window or the  button on the main panel.

SHUTTING THE PRINTER DOWN

● **REGULAR MODE (FOR UP TO 1 WEEK)**

**SWITCH THE POWER OFF
ARE YOU SURE (Y,N)?**

(Y=ENTER, N=ESC)

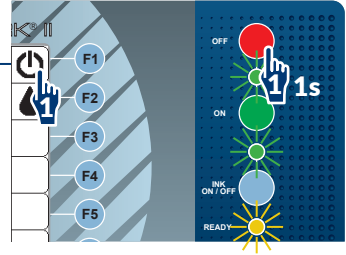

The procedure for shutting the printer down follows.

Time required to complete the procedure.

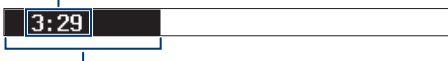

Progress bar.



SWITCHING THE PRINTER OFF

.....
Press ENTER...

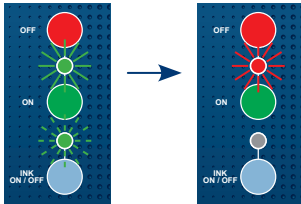

Printer in standby mode.

Turn the power off,
if need be.

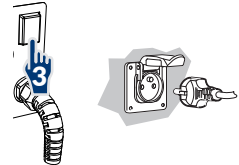

POWER → „O”

● **EMERGENCY SHUTDOWN MODE (FOR UP TO 1 HOUR)**



Hold down.



Press once and hold
down over 1s.

or



POWER → „O”



The printer can be shut down in emergency shutdown mode only when a clear failure of the printer occurs and a few minutes' shutting down in regular mode could cause further damage (e.g. ink spill).



On shutting the printer down in emergency shutdown mode, wash the printhead interior (especially the gutter area) with solvent.

• OPERATOR

When the BOLTMARK® II-series printer starts up, the following functions available to OPERATOR  can be used, as standard:



to select a text for printing/the active text,



to start/stop printing a selected text,



to log in/log out OPERATOR /ADVANCED OPERATOR /SERVICEMAN ,



to stop/start ink flow,



to clear an alarm,



to shut the printer down.

To gain access to a greater number of functions described further in this document, the user should log in as:

- ADVANCED OPERATOR 
- SERVICEMAN 

• LOGGING IN

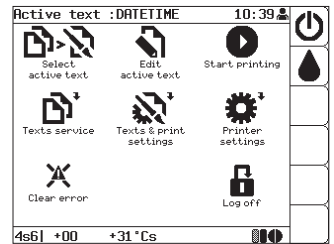
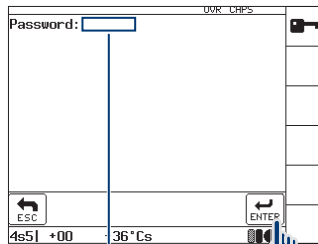
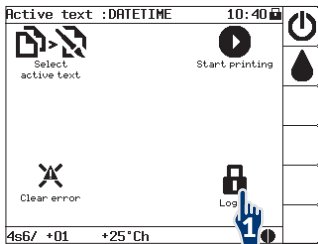



2 Type in a text via the keyboard.





- The default password of ADVANCED OPERATOR  is ebs.
- If the a/m password is not defined, ADVANCED OPERATOR  is logged in when the printer starts up.

● TOUCH PANEL

Types of menu icons:

- functions, e.g. 
- function folders - the functions are marked with ↴, e.g. 



Additional navigation icons:

-  to return to the previous menu level
 -  to go to the main screen
 -  to return to the recently used menu level (from the main screen)
- in working window
- on function identification icon bar
- on function identification icon bar

● KEYBOARD

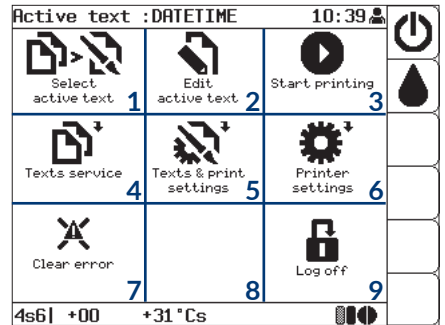
The working window is divided into 9 sections. Every section is associated with a keyboard digit; the digit works as a hot key.



 4 to open folder 

 8 no response - no function or folder in section 8,

    to move among sections, to highlight a selected section,

 to perform an operation in the highlighted section,

 to return to the previous level.

Possibilities for creating a new text.

Text contents:

- special registers: the time, the date, the expiration date, object counters, etc,
- bar codes: standard and 2D "Data Matrix" codes,
- graphics: built-in/created by a user (with a graphics editor).

Text profiles:

- texts can be edited more easily because they are adjusted to a required configuration,
- print quality and printing speed are optimized.

All printer operation stages are described based on an example:

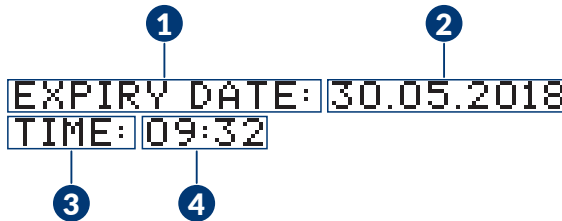

The text consists of 4 subtexts:

- | | |
|-----------------------------------------------------------------------------------------------------------------|-------------------------------------------------------------------------------------------------------------------------------------------------------------------|
| <p>1 Text.</p> <p>2 Special register Date+offs.</p> <p>3 Text.</p> <p>4 Special register Time</p> | <p>Static text.</p> <p>Dynamic text. Current date + the value of the Offset printing parameter.</p> <p>Static text.</p> <p>Dynamic text. Current time.</p> |
|-----------------------------------------------------------------------------------------------------------------|-------------------------------------------------------------------------------------------------------------------------------------------------------------------|

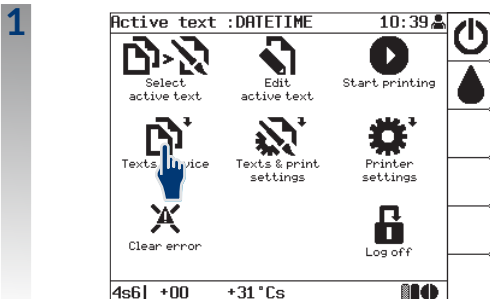

Open folder

2

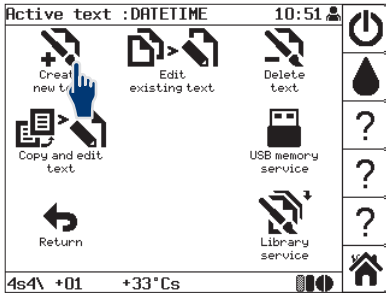

Select 

3

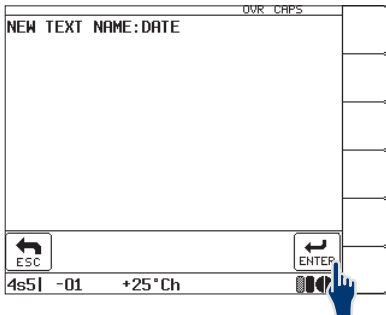

Type in a text name.
Up to 8 characters - capital/small letters, digits and characters excluding ., / \ ; : * < > | [] { } = +, e.g. DATE.

Confirm by pressing 

4

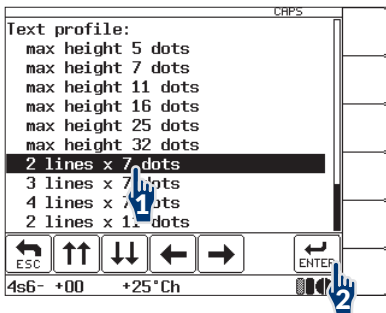



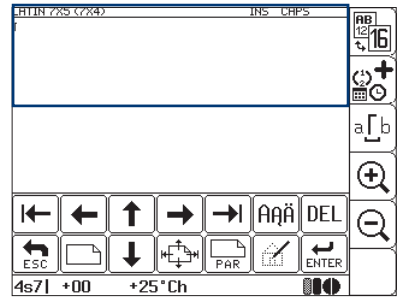

Select a text profile.
The highlighted profile **2 lines x 7 dots** is optimal in this case.

Confirm by pressing 

5 Editor - a new empty window.



6  Set parameters for subtext 1.

	Type : Text
	Char. set : Latin 7x5  
	Typeface : Normal
	Chr. width : Proportional
	Distance : 2
	Rotation : None
	Spec. reg. : None
	Front dist : 0
	Back dist : 0





Type in a text via the keyboard.



Create subtext 2 to the right of the previous one.

7  **Date+offs.** 

Use the special register creator to set up subtext 2 as a **Date+offs.** () special register.

 The other parameters of subtext 2 - as for subtext 1.



The expiry date (the **Date+offs.** special register) is printed correctly when the **Offset** and **Offset interv** printing parameters are set.

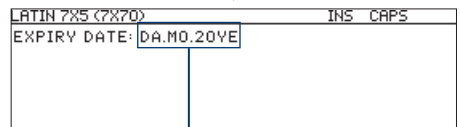

Type in a text via the keyboard.



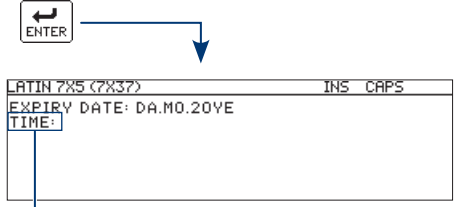

Create subtext 3 below the previous one.

8  Set parameters for subtext 3 the same as for subtext 1.



Type in a text via the keyboard.

  Create subtext 4 to the right of the previous one.

9   Time 

Use the special register creator to set up subtext 4 as a Time (L) special register.

 The other parameters of subtext 4 - as for subtext 2.

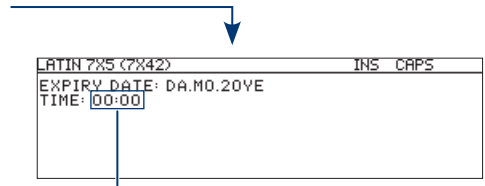

Type in a text via the keyboard.























In the subtexts where special registers (2 and 4) are used, letters typed in for the date and digits typed in for the time are replaced with values during printing (e.g. DA - tens and units of the 2-digit day number in month, MO - tens and units of the 2-digit month number in year, YE - tens and units of the 2-digit year number).

10  To confirm the end of text editing (the text is saved to text library).

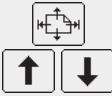
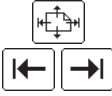
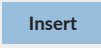
The above example contains only certain option out of those available in the text editor.

Other useful functions:

Buttons / Icons	Function
	To inform about the current profile of the edited (highlighted) text and the possibility of changing the profile. Special register creator; to set up a selected subtext as a special register. If the selected subtext is a special register, then the icon indicating the type of special register is displayed in place of the creator icon in the editor window: Up counter  , Down count.  , Time  , Date  , Spec. chan.  , Univ.count.  , Univ. date  , Date+offs.  , WILL Date  , Variable Field  , Text content 
	To switch over the space display mode. The space characters can be displayed as the prearranged character '[' (as standard) or as empty columns. Regardless of the display mode enabled, spaces are always printed as empty columns.
	To increase the preview scale of the edited text.
	To decrease the preview scale of the edited text.
	To shift the cursor to the first or last character of a subtext.
	To shift an entire subtext by one pixel up or down (or to shift a subtext to the previous/following line).
	To shift a subtext by one subtext left or right.
	To switch over the character insertion mode: INS ert/ OV erwrite.
	To delete the subtext character at the current cursor position.
	To delete the entire current subtext.
	To open graphics editor (available only when Type = Graphic).
	To select a language.



Printing parameters apply to the active text. The selection of another text as the active text does not involve any change in printing parameters on condition that the new active text is not linked with a parameter block. If the new active text is linked with a parameter block, the parameters contained in the linked block are read in when the new text is selected as active.

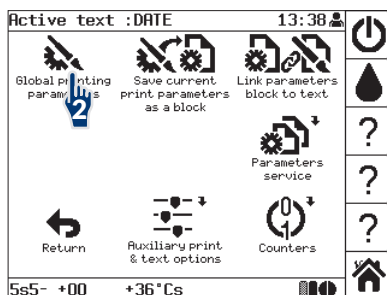
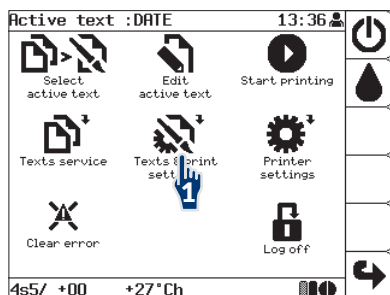

To scroll the screen.



To go to the previous/next item.



To change the parameter settings (the values of numerical parameters can be typed in via the keyboard).



To confirm.



To select a text from the library (it applies to the **Active text** parameter).

Immediately after the printing parameters have been edited (and the modifications confirmed by pressing the  icon) they can be saved to a block. The suggested name for a parameter block is the same as the name of the active text.



To avoid the need for setting parameters for every text, you can save printing parameters as a block and then link a text with the parameter block by pressing



Active text : DATE	The name of the active/printed text.
Linked param. :	The name of a parameter block linked with the active text.
Height (pix) : 16	The height of the active/printed text; it is given as a number of dots.
Matrix height : LARGE	A rough adjustment of print height by selecting one of the pre-defined height settings.
Print height : 100%	Recommended setting: 100% . A description of the parameter is given in The BOLTMARK® II-series Printers User Manual .
Speed Level : SLOW 29.2m/min	A speed level is selected for obtaining the optimum print quality (SLOW) or the maximum traveling speed of the conveyor belt (FAST). The parameter also gives the maximum traveling speed of the conveyor belt for a selected printing algorithm. For Generator = GEN , the a/m speed is the maximum value of the Cnv spd m/min parameter.
Generator : GEN 10.020 m/min SHAFT 0.000 m/min	The source of timing signals: an internal generator or a shaft-encoder. The parameter also gives the current conveyor belt travel speed. For Generator = GEN , the a/m speed is close to the value of the Cnv spd m/min parameter. For Generator = SHAFT , the a/m speed equals conveyor belt travel speed measured.
Resol. dot/cm : 20 (20.00) 0%	The setting of print resolution in the horizontal direction. For Generator = SHAFT , except for the resolution setting, also real resolution and the difference between resolution setting and real resolution [in %] are given.
Cnv spd m/min : 10.0	For Generator = GEN , conveyor belt travel speed is given. The speed cannot be higher than the value given via the Speed Level parameter.
Enc const p/m : 10000 (xx)	The real (and virtual) number of pulses transferred by the shaft-encoder per unit of length. To adjust printing speed to conveyor belt travel speed (if Generator = SHAFT).
Vert. direct. : STANDARD	Vertical direction of printing: standard, diverted.
Space : 2.0 mm	Space between the beginning of an object and the beginning of the print.
Space2 : ---	Optional parameter.

Text rpt. : 1	The number of reprints of a text on an object.
Rpt.dist. : 30,0 mm	Distance between the beginnings of successive reprints (if Text rpt. > 1).
Conv. direct. : LEFT	The direction (left, right) in which objects move in front of the printhead.
Offset interv. : Day	A unit by which the date to be printed is shifted relative to the current date. The parameter is used to print a so called expiration date by the application of the special register Date+offs.
Offset : 100	A value by which the date to be printed is shifted relative to the current date; it is given in units selected with the printing parameter Offset interv. The parameter is used to print a so called expiration date by the application of the special register Date+offs.
RollTimeHH:MM : 00:00	Setting forward the time at which the date change occurs, from noon to another time during the day. The parameter is used to print the date by means of the special register WILL Date.
Counter delta : 1	Increment for an incremental counter or decrement for a decremental counter. The parameter is used by the Up counter and Down count. special registers.
Row repetit. : 1	The number of reprints of every column of a text.
Print every n :	Optional parameter.
Mode : NORMAL	To activate printing at maximum speed. The parameter is available only for SERVICEMAN  .



- Not every combination of the **Matrix height**, **Speed Level** and **Height (pix)** parameters is permitted. If a forbidden combination is selected, an error message is displayed. To display the whole message, select the  icon on the function identification icon bar.
- If you find it difficult to set the global printing parameters, it is recommended that the default parameter settings be applied by pressing the  icon. Most of texts can be printed at the default settings of the printing parameters.
- If **Generator = GEN**, an object must move in front of the printhead so that a correct print is made. Otherwise, a vertical bar is printed.
- If **Generator = SHAFT**, the printhead will print only when a rotary encoder is connected to the conveyor belt and the belt travels.

1

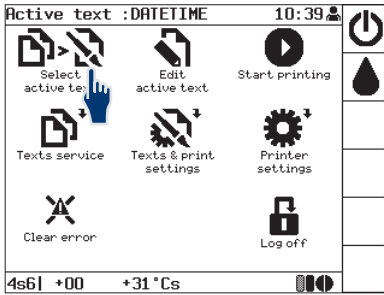

Select 

2

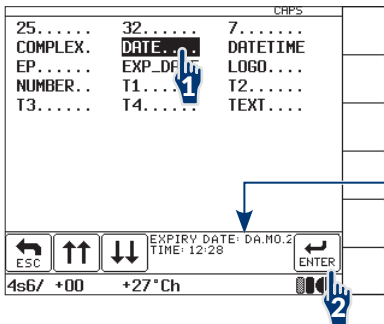

Select a text from the library.

Preview of the selected text.

Confirm by pressing 

3

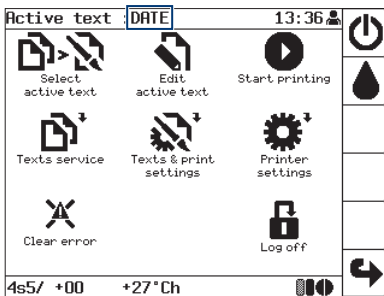

The name of the active text is displayed on the information bar.

1



To start printing the active text.

The button can be used regardless of what screen is currently displayed (e.g. while a text is edited).



To start printing the active text or any text selected from the library.

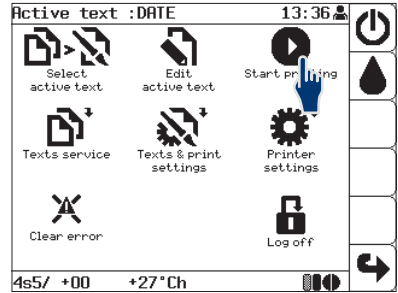

2

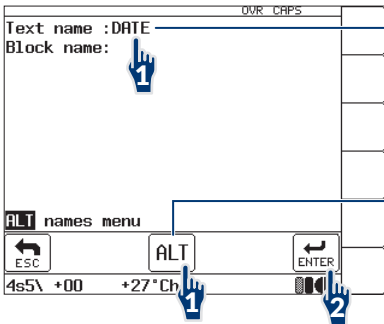

Type in a text name.

Up to 8 characters - capital/small letters, digits and characters excluding ., / \ ; : * < > | [] { } = +, e.g. DATE.

or

Select a text to print from the library.

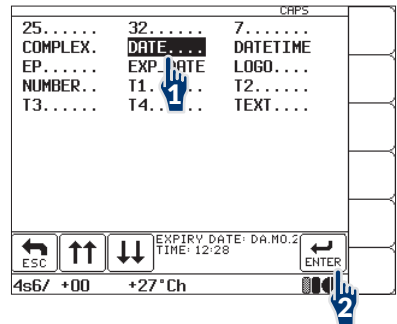

3

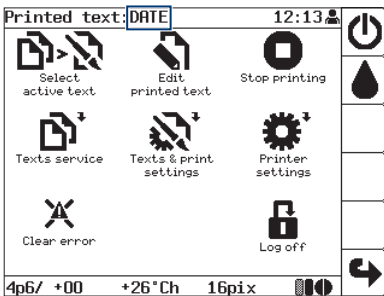

p - print

Height (in dots) of the printed text.

The name of the printed text is displayed on the information bar.

● **PREVIEWING THE PRINTED TEXT**

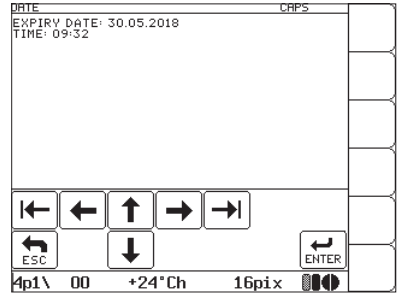
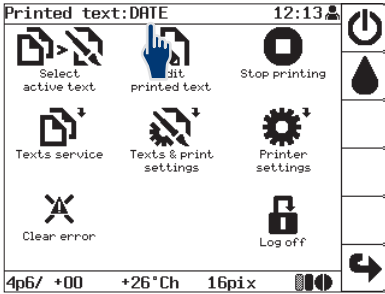

● **FINISHING PRINTING**

Pausing printing in regular mode.

Select .

Printing pauses after printing of the current text has finished.

**STOP PRINTING
ARE YOU SURE (Y,N)?**

(Y=ENTER, N=ESC)

Confirm .

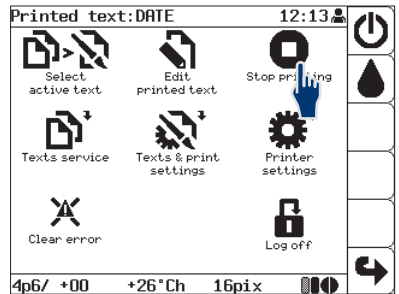

Pausing printing in immediate mode.

Select .

Printing pauses immediately. The button can be used regardless of what screen is currently displayed (e.g. while a text is edited).



Signaling of pausing of printing

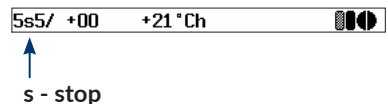

Emptying of a bottle is signaled with an audible alarm signal, the **ERROR** LED on the operator panel illuminating blinking red, the display background flickering red and an error message:

SOLVENT LACK

or
SOLVENT: EMPTY BOTTLE

INK LACK

or
INK: EMPTY BOTTLE

The bottle should be replaced immediately after the above signaling has occurred. The operation can be performed also during printing. Otherwise, if the correct ink parameters cannot be maintained or if the ink level in iModule® reduces too much, printing is paused, and the printer is shut down.

1

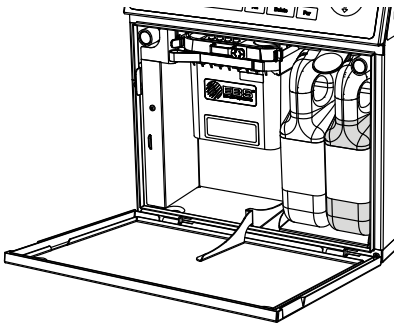

Open the consumables compartment door.



While replacing bottles, be careful not to get wounded with the needles that are part of the bottles connections in the consumables compartment.

2

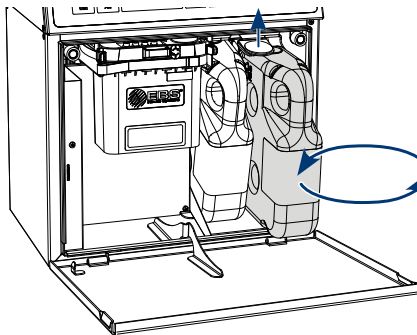

Lift the latch.

3

Take the empty bottle out; signaling:
INK: NO BOTTLE
or
SOLVENT: NO BOTTLE

4

Insert a new bottle; signaling:
CODE VERIFYING: WAIT 10 SECONDS PLEASE
and then
BOTTLE ACCEPTED

5

Close the consumables compartment door.

While maintaining the printhead, check the printhead interior for cleanliness approximately once a month and remove dirt, if need be.



Any operations that involve the removal of printhead cover during printer operation must be performed exclusively by the manufacturer's authorized service staff or a user trained by the manufacturer's authorized representatives in performing such operations. An untrained user can remove printhead cover exclusively when the printer is disconnected from the electric mains.

1 Remove the printhead cover:

Loosen the screw that fastens the printhead cover.

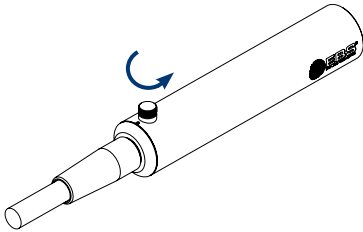

Pull the printhead out of the cover.

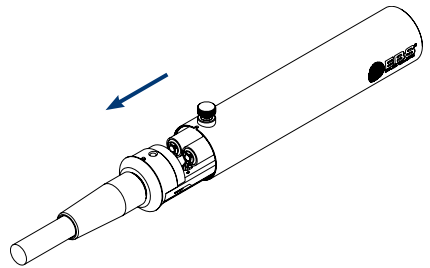

2 Check the printhead interior for cleanliness.

If no dirt needs removing from the printhead, then insert the printhead into the cover, screw home the fastening screw and resume normal operation.

3 Stop ink flow in the printhead.

Stopping in regular mode.

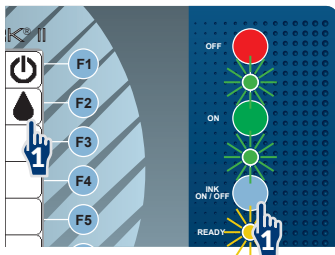

Ink flow is stopped when the ink flow LED does not illuminate.

If the printhead needs to be cleaned quickly, follow the brief procedure for stopping ink flow.

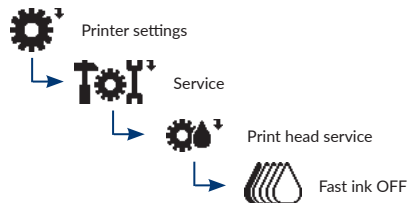

4 Place the printhead in a metal vessel (a drip pan).

5 Remove any remnants of ink from the electrodes, the nozzle and the gutter area with solvent (by means of a sprayer). A compressed air gun can also be used.

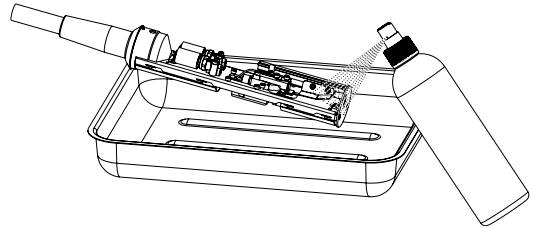

6 Start ink flow in the printhead.

Starting in regular mode.

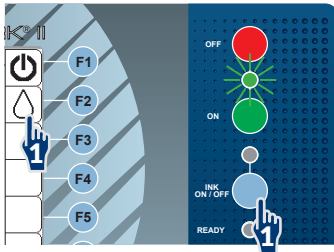

If the printhead needs to be started quickly, follow the brief procedure for starting ink flow.

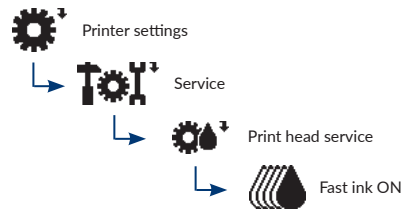

Ink flow is activated when the ink flow LED illuminates.

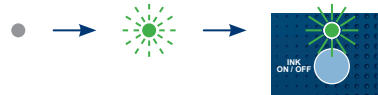

7 Insert the printhead into the cover, screw home the fastening screw and resume normal operation.



- While installing the printhead cover make sure that the fastening screw is screwed home firmly; the screw provides not only mechanical fastening but electrical connection between the cover and the printer housing, as well.
- The printhead is equipped with a sensor that detects the removed cover condition. On loosening the screw that fastens the printhead cover, printing pauses automatically and the printer enters service mode (v). `4v2\ +00 +38°Cs` Printing cannot be resumed until the cover is reinstalled and the fastening screw is screwed home.



Manufacturer:



EBS Ink Jet Systeme GmbH
Alte Ziegelei 19-25,
D-51588 Nümbrecht-Elsenroth.

tel. +49 (0)2293 / 939-0,
fax +49 (0)2293 / 939-3.

Customer Service/Reception/Commercial Department: mail@ebs-inkjet.de
WWW: <http://www.ebs-inkjet.de>

		Version Review
Instructions version	Date of publication	Version of main control program
20170328#1.0EN	28.03.2017	36_0A
2017/05/04#1.1EN	04.05.2017	36_0A
2018/02/27#2.0EN	27.02.2018	37_1A