



**EBS**  
Ink Jet Systems

# **EBS 1500 series**

---

**USER'S MANUAL**

*Ink-Jet technology for the future*





INK JET PRINTERS

# EBS-1500

USER'S MANUAL  
WITH A SINGLE ELECTROMAGNETIC HEAD

VERSION 20060920#3.1



**EBS Ink-Jet Systems GmbH**  
Alte Ziegelei 19-25, D-51588 Nümbrecht

 +49 (0)2293 / 939-0

Fax +49 (0)2293 / 939-3

<http://www.ebs-inkjet.de>

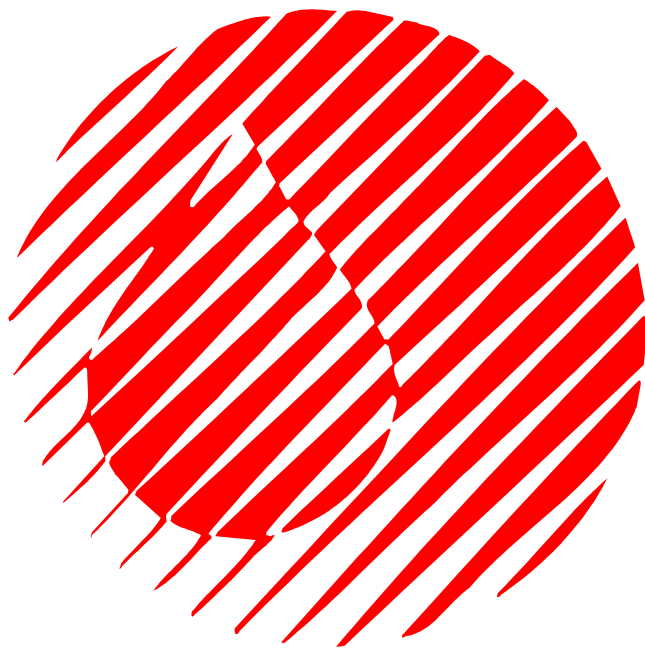

©2006 EBS Ink-Jet Systems GmbH, D-51588 Nümbrecht

## TABLE OF CONTENTS

<b>1. GENERAL INFORMATION .....</b>	<b>7</b>
1.1. ENVIRONMENTAL PROTECTION .....	7
1.2. APPLICATION .....	7
<i>Short Description of the Printer: .....</i>	<i>7</i>
<b><i>EBS-1500</i></b> Print Heads .....	<b><i>8</i></b>
<b><i>EBS-1500</i></b> General-purpose Controller .....	<b><i>9</i></b>
1.3. PRINCIPLE OF OPERATION .....	10
<i>Electromagnetic Print Heads .....</i>	<i>10</i>
<b>2. INSTALLING THE PRINTER.....</b>	<b>11</b>
2.1. SAFETY REQUIREMENTS .....	11
2.2. POWER AND AIR SUPPLY REQUIREMENTS .....	12
Power Supply .....	12
Air Supply.....	12
2.3. INSTALLING THE UNIT .....	12
2.3.1. Printer accessories .....	12
2.3.2. Preparatory Steps .....	13
2.3.3. Removing Transport Protections .....	14
2.3.4. Connections.....	14
<i>Earthed neutral system.....</i>	<i>15</i>
<i>Connecting the head .....</i>	<i>15</i>
<i>Connecting the photo detector .....</i>	<i>15</i>
<i>Connecting the shaft-encoder .....</i>	<i>16</i>
<i>Connecting external data transfer devices .....</i>	<i>16</i>
<i>Connecting the Ink Monitor System - IMS.....</i>	<i>16</i>
<i>Connecting the head to the ink and compressed air systems.....</i>	<i>16</i>
<i>Connecting the head to the pump-based ink system .....</i>	<i>18</i>
2.3.5. Installing a new Bottle of Ink (or Replacing an Empty One) .....	18
<i>Connecting a new ink bottle (or replacing an ink bottle) in the compressor-</i>	
<i>based system .....</i>	<i>18</i>
<i>Connecting a new ink bottle (or replacing an ink bottle) in the ink system</i>	
<i>with an ink pump.....</i>	<i>19</i>
2.4. REMOVING THE HEAD COVER.....	19
<b>3. STARTING THE PRINTER.....</b>	<b>20</b>
3.1. SWITCHING THE PRINTER ON .....	20
3.2. SWITCHING THE PRINTER OFF .....	20
<b>4. OPERATING THE PRINTER.....</b>	<b>21</b>
4.1. OPERATION PANEL.....	21
4.2. OPERATING THE PRINTER WITH CONTROL MENU.....	23
4.3. PRINT HEAD STATUS .....	26
4.4. CONTROLLING THE PRINTER .....	27
4.4.1. Text Files .....	27
4.4.1.1. Introduction to Text Files .....	27
<i>WORD PROCESSOR – A Description of Control Keys.....</i>	<i>28</i>
4.4.1.2. Opening and Editing a New File .....	29
<i>Subfile type: TEKST – ASCII characters.....</i>	<i>29</i>
<i>Subfile type: GRAPHICS.....</i>	<i>31</i>
<i>GRAPHIC PROCESSOR – A description of function keys.....</i>	<i>32</i>

	Subfile type: BAR CODE .....	33
	Subfile type: Text file Name .....	34
4.4.1.3.	Editing an Existing Subfile .....	35
4.4.1.4.	Copying and Editing a Text file .....	35
4.4.1.5.	Deleting a Text file .....	35
4.4.1.6.	Deleting the File Library .....	36
4.4.1.7.	Accessing the File Library .....	36
4.4.1.8.	Linking File Names with Parameter-block Names .....	37
4.4.1.9.	Using the Password .....	37
	Defining a User Password .....	37
	Switching the Password Function On .....	38
	Changing the User Password .....	38
	Deleting the user password .....	38
4.4.1.10.	Using Special Registers .....	39
	Object Counters .....	39
	Date and Time .....	40
	Universal Counter .....	41
	Universal Date and Time .....	46
	Expiry Date Registers .....	47
	Data from Special Channel .....	48
<b>4.4.2.</b>	<b>Using Print-parameter Blocks .....</b>	<b>48</b>
4.4.2.1.	Creating and Editing a New Parameter Block .....	49
	Modifying Parameters .....	49
4.4.2.2.	Editing Existing Blocks of Parameters .....	50
4.4.2.3.	Copying and Editing Blocks of Parameter .....	50
4.4.2.4.	Deleting a Block of Parameters .....	50
4.4.2.5.	Deleting the Parameter-block Library .....	50
4.4.2.6.	Accessing the Parameter Block Library .....	51
<b>4.4.3.</b>	<b>Printing .....</b>	<b>52</b>
4.4.3.1.	Stopping the Printing .....	52
4.4.3.2.	Starting the Printing .....	52
4.4.3.3.	Quick Stopping the Printing .....	53
4.4.3.4.	Print Parameters .....	53
	Modifying Print Parameters .....	54
	Vertical Direction .....	55
	Initial Distance .....	55
	Number of Repetitions .....	55
	Distance Between Overprints .....	56
	Horizontal Direction .....	56
	Overprint Height .....	57
	Date Offset .....	58
	Counter Increment .....	58
	Row Repetition .....	58
	Ink drop Intensity .....	59
	Timing Mode .....	59
	Character Resolution .....	59
	Conveyor travel speed .....	60
	Number of Pulses Generated by External Encoder .....	60
	Number of purging rows during the automatic nozzle-purge procedure .....	60
	Purge period during the automatic nozzle-purge procedure .....	61
4.4.3.5.	Saving Current Parameters in a Block .....	61
4.4.3.6.	Controlling Object Counters .....	62
	Accessing object counters .....	62
	Modifying Object Counters .....	62
4.4.3.7.	Printing with the use of a code switch .....	63
4.4.3.8.	Viewing Files on the Terminal Display .....	63
<b>4.4.4.</b>	<b>Servicing the Head .....</b>	<b>64</b>
4.4.4.1.	Defining Some Print Parameters with the Conveyor Travel Speed .....	64
4.4.4.2.	Other Commands .....	64
<b>4.4.5.</b>	<b>Auxiliary Commands .....</b>	<b>65</b>

4.4.5.1.	System information .....	65
4.4.5.2.	Accessing Alarm Messages.....	65
4.4.5.3.	Setting Date and Time .....	65
4.4.5.4.	Checking the Printer Run Hours .....	66
4.4.5.5.	Choosing a Language.....	66
4.4.5.6.	Releasing Protections .....	66
<b>4.4.6.</b>	<b>Replacing ink bottle .....</b>	<b>68</b>
	<i>General information .....</i>	<i>68</i>
	<i>Replacing the bottle of ink .....</i>	<i>69</i>
4.4.6.1.	Checking the validity date.....	70
4.4.6.2.	Checking the calculated ink consumption level .....	71
4.4.6.3.	Accessing information in the Ink Monitoring System.....	71
4.4.6.4.	Problems that might arise in the printer operation when a bottle of ink is replaced .....	72
	<i>Flow diagram for the ink monitoring system.....</i>	<i>72</i>
<b>4.5.</b>	<b>ALARMS, ERRORS AND INDICATIONS .....</b>	<b>73</b>
4.5.1.	Clearing Alarms .....	75
<b>4.6.</b>	<b>ADJUSTING THE PRINT RATE.....</b>	<b>75</b>
4.6.1.	Internal Generator .....	75
4.6.2.	Shaft-encoder .....	76
4.6.3.	Defining the Maximum Print Rate for Various Fonts.....	78
<b>5.</b>	<b>EXAMPLES OF HOW TO OPERATE THE PRINTER .....</b>	<b>79</b>
5.1.	HOW TO PRINT THE FIRST SAMPLE TEXT FILE? .....	79
5.2.	CREATING AND PRINTING SAMPLE TEXT FILES .....	81
5.2.1.	How to Print the Current Date and Time?.....	81
5.2.2.	How to Print Consecutive Numbers?.....	82
5.2.3.	How to Print Expiry Date? .....	83
5.2.4.	How to Print Logos? .....	84
5.2.5.	How to Print a Bar Code?.....	85
5.2.6.	How to Print a Complex Subfile?.....	85
<b>6.</b>	<b>SERVICING AND MAINTENANCE OF THE PRINTER .....</b>	<b>88</b>
6.1.	ROUTINE MAINTENANCE .....	88
6.2.	REMOVING AIR FROM THE INK SYSTEM.....	89
6.3.	REPLACING THE INK FILTER .....	89
6.4.	WHEN PROBLEMS ARISE WHILE OPERATING OR SERVICING THE PRINTER .....	89
	The printer does not switch on .....	89
	No overprints are made after the print command has been accepted .....	90
	Clogged nozzles in the head .....	90
	Some dots are much smaller than others or are missing.....	91
	<i>Adjusting valve electromagnets in electromagnetic heads .....</i>	<i>91</i>
	Overprints are distorted .....	93
	Overprints made with the electromagnetic head look like printed in bold and blurred .....	95
	Overprints are slanted .....	95
	Lower (upper) parts of overprints are distorted.....	96
	Some vertical rows are missing in overprints.....	96
	Overprints are not straight, they are wavy or jagged.....	97
	Mixed text names in the library – the battery is discharged.....	97
6.5.	HOW TO CONTACT YOUR SERVICE REPRESENTATIVE? .....	98
<b>7.</b>	<b>STORAGE AND TRANSPORTATION .....</b>	<b>99</b>
7.1.	STORING THE PRINTER .....	99
7.2.	TRANSPORTING THE PRINTER .....	100

<b>8. MULTI-HEAD INK-JET PRINTERS.....</b>	<b>101</b>
<b>9. TECHNICAL SPECIFICATIONS .....</b>	<b>102</b>
<b>APPENDIX A - LAYOUT OF CYRILLIC CHARACTERS ON THE PRINTER                   TERMINAL KEYPAD .....</b>	<b>105</b>
<b>APPENDIX B - LAYOUT OF ARABIC CHARACTERS ON THE PRINTER                   TERMINAL KEYPAD .....</b>	<b>106</b>
<b>Index.....</b>	<b>107</b>

***Dear User,***

***This Manual contains very useful information on how to operate your Ink-Jet Printer. Please read this Manual carefully.***

This version (3.1) of the document applies to EBS-1500 printers with a single electromagnetic head and is the continuation of the operating instructions (version 20.8), which applied to EBS-1500 printers with all head types, including multi-head systems. The document incorporates most changes introduced to EBS printers in software versions from 16\_1A to 21\_0A and the descriptions contained therein apply to the equipment where such software versions are installed.

As the machine and options can be customised, the product delivered to you depends on your specific order. Therefore some descriptions or illustrations may differ slightly from your equipment. As we need to keep pace with new technological advancement, we reserve the right to introduce changes in the design and technical solutions adopted. In view of the above, no data, illustrations or description shall make grounds for any claims. Should your printer be equipped with options that are not described or illustrated in the Manual or should you have additional queries after having read the Manual, please contact any EBS representative for more information.



## 1. General Information

### NOTE:

There are warning and information signs on the right or left hand-side margins of some pages to attract user's attention to messages that are provided next to them. They are the following signs:



Information signs indicating:

- that the actions described should be taken carefully,
- additional, printer-specific option and features,
- untypical behaviour of the unit,
- other hints.



**A warning not to take the action that might have a critical impact on the proper operation of the unit. It requires the user to follow closely instructions given therein.**

**The Manufacturer reserves the right to introduce changes whose description may not be provided in this manual.  
The Manufacturer shall not bear any responsibility for damages resulting from the failure to follow the instructions or consequences of editorial or publishing errors within the instructions.**



### 1.1. Environmental protection

On withdrawing **EBS-1500** printers and printing systems from use do not take system elements out together with other waste. Pursuant to Directive No. **2002/96/EC** of the Council of the European Community on waste electrical or electronic equipment, the elements of the **EBS-1500** printers and printing systems must be separated from other waste after they have been withdrawn from use and processed in an environmentally friendly way.



### 1.2. Application

**EBS-1500** is a family of industrial **INK JET** printers designed for labelling in a non-contact way, various objects that move on a line conveyor, for example. The printer provides clear and firm overprints on such materials as:

- paper and cardboard,
- (porous) plastics,
- fabric,
- leather and leatherette,
- wood and wood-like products,
- (porous) ceramic products,
- metal surfaces of any type, etc.

#### ***Short Description of the Printer:***

Every **EBS-1500** series printer consists of a general-purpose controller and a print head.

## ***EBS-1500*** Print Heads

The print heads have the following traits:

- They are independent on the controller and therefore the heads can be installed closely next to the object being labelled, which is not in an easily accessible place very often.
- They are connected with the controller via a **3 m** long flexible cord as a standard (up to **30 m** optionally).

1500/00 series electromagnetic heads, where the nozzle valve is controlled with an electromagnet. One head can contain 5, 7, 12, 16, 25, 32 or 64 nozzles. A printer equipped with such heads can produce 6 to 115 mm high overprints with one head.

- The electromagnetic head can be set at any position.
- Inks of various types and colours can be used according to the surface to be printed on.



Electromagnetic **7 to 16-nozzle** head



Electromagnetic **25 to 32-nozzle** head



Electromagnetic **64-nozzle** head

**EBS-1500 General-purpose Controller**



The controller has the following traits:

- Separate controller types for electromagnetic or piezoceramic print head families.
- Splash-proof stainless steel INOX housing and a membrane keypad to ensure that the controller is resistant to water and all types of solvent that might be used in the real working environment.
- All connectors grouped on the same side wall to facilitate the installation of the printer in a place where the space is very limited.
- Printing capabilities:
  - texts composed of small and capital letters of various types, also printed in boldface or rotated,



- several lines of text printed during a single run of an object in front of the print head (a maximum of 6 lines with no space between the lines),

4 lines (7x5)	1-INK-JET 2-EBS-1500 3-INK-JET 4-EBS-1500	5 lines (5x5)	1-INK-JET 2-EBS-1500 3-INK-JET 4-EBS-1500 5-INK-JET	6 lines (5x5)	1-INK-JET 2-EBS-1500 3-INK-JET 4-EBS-1500 5-INK-JET 6-EBS-1500
---------------------	----------------------------------------------------	---------------------	-----------------------------------------------------------------	---------------------	-------------------------------------------------------------------------------

- diacritical national characters,
- graphics – a built-in set of ready-to-use graphic signs and a tool-kit for creating user-defined graphics,



- bar codes of various kinds, printed in a regular way or in reverse, with or without a caption of digits; an option of introducing on-going changes to the digital contents of the code (bar code as an incremental or decremental counter)





12345670



123456789012

- variable data - such as current date, warranty expiration date, current time, ascending and descending numbering (counters), any types of data, which are transferred from a PC or external devices (via an optional special channel), as required and arranged by the user.
- Labels can be input or modified easily with the use of a built-in terminal or a PC (via RS-232 or RS-485 interface).
  - An optional **PC** can be connected in order to:
    - control the operation of one printer via the program **EdGraf**.
    - allow a number of **EBS** printers of various types, linked together into a network, to be controlled from one computer via the program **InkNet**.
  - Objects to be labelled are detected by a photo-detector.
  - Fully automatic printer's operation with the status indication and instructions for performing service operations.
  - Bottles of ink are fully controlled and bottles designed for different, incompatible types of EBS printers are not accepted.
  - Continuous operation over 24 hours a day.

### 1.3. Principle of Operation

#### *Electromagnetic Print Heads*

Every label consists of a number of a droplet-wide vertical rows. Nozzles are set in the print head vertically, at regular intervals from each-other. This determines the maximal height of the label. Every nozzle is equipped with an electromagnet-controlled valve. Labels are made by ink droplets that are jetted at a pressure when the valves open. The pressure is generated by an external system and controlled with a pressure regulator. Objects to be labelled move in front of the print head and vertical rows are printed one by one to complete the entire label.

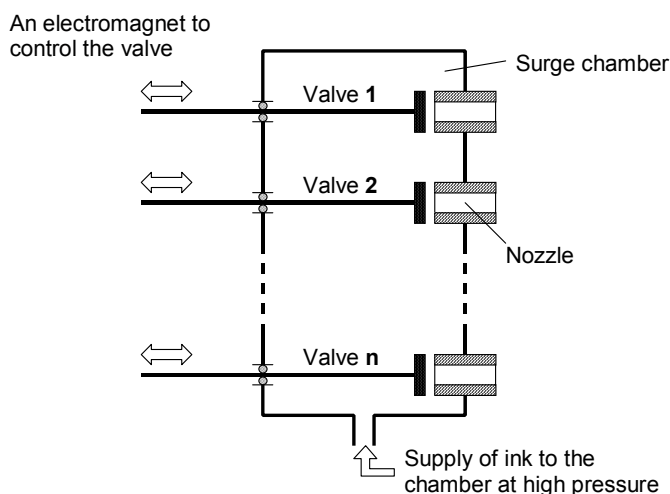

## 2. Installing the Printer

### 2.1. Safety Requirements

All efforts have been put into designing this device carefully and making it safe and reliable. However, the safe operation of the device is conditioned by the user's awareness of, and obedience to the following safety rules and precautions.

**The unit should be operated by the staff that has been trained.** It is recommended that the operation of the printer is supervised.



- 1. A fire extinguisher designed to extinguish electrical equipment and flammable solvent fire must be placed within easy reach near the unit.**
- 2. The unit must not be operated in rooms where an explosion hazard exists.**
- 3. The unit must not make overprints on objects whose temperature exceeds 100 °C.**
- 4. No open fire or spark producing devices are allowed in the area where the printer operates.**
- 5. Power supply cord must be connected to a socket where a protective pin is used.** The efficiency of the earth should comply with the applicable standards.
- 6. As high voltage occurs in the printer, make sure that all manipulations in the electrical part of the system and inside the head are performed after power has been switched off.**
- 7. The outlet of the head must not be directed towards persons, animals or accidental objects during printing in order to avoid splashing anybody or anything with ink.**
- 8. Protective clothes** and possibly protective glasses **need to be worn** by persons performing **any work** on the ink system.
- 9. No plastic vessels should be used to do the washing** as they collect static electricity. Metal vessels are recommended.
- 10. No ink, solvent or wash-up** (or waste fluid remaining after the head has been washed) **should be left in open vessels** as these inflammable fluids may ignite from accidental sources of fire.

#### **WARNING:**

Static electricity collected by people (on their plastic clothes or in their hair, for example) may spark-over to ink or wash-up vessels when they have been left open. **The ink and wash-up are inflammable and may get ignited!** Therefore, before you approach the open vessels with inflammable fluids, discharge the static electricity by touching the metal printer housing or another metal object that is connected to the earth.



#### **In the case of accident...**

- When ink or solvent spills occur, the spilled fluid should be wiped with a piece of absorbent material and then removed in compliance with fire and health and safety at work (HSE) regulations.
- If the clothing has been splashed, remove it as soon as possible.
- Should the eyes or skin get irritated:
  - EYES** need to be rinsed with running water for at least 15 minutes, then you should see your oculist,
  - SKIN** needs to be washed with water and soap.



## 2.2. Power and Air Supply Requirements

### Power Supply

	Standard
Supply voltage	100 - 240V (AC) 90 - 350V (DC)
Mains frequency	45 - 440Hz



**NOTE:**

- The mains electricity must meet the requirements of the applicable standards. Otherwise measures need to be taken or devices used to ensure that the proper power is applied to the printer.
- **The mains socket should be equipped with a protective pin properly connected to earth. The efficiency of the earth needs to comply with the applicable standards.**

### Air Supply

Ink pressure can be generated by an external compressor system or inside the ink system if the system is equipped with an ink pump. The application of the ink system with a pump simplifies the structure of the printing system significantly. A detailed description of the device is contained in the document entitled *Ink System with an Ink Pump*.

**Regulator inlet air pressure:** 0,5 - 10 bar (0,05 - 1,0 MPa).



**NOTE:**

If a compressor system is used, supply air must be free from any impurities. Otherwise ink gets dirty sooner inside the ink system and overprints of lower quality may result.

If air supplied from the compressor system is likely to contain any of the above-mentioned substances, filtering elements absolutely need to be installed immediately before the ink system connection to remove such impurities as water, oil or others.

**The Manufacturer shall not bear any responsibility for improper operation of the unit, if the malfunction is caused by air contamination.**

## 2.3. Installing the unit

### 2.3.1. Printer accessories

In view of a great number of EBS printers and printing systems, the set of accessories depends on a specific user application. This section gives a specification of the accessories that are used most frequently in various printer configurations.

Typical printer accessories include:

- a). Elements and units which are needed for the printing process in every configuration,
- b). Additional and supportive elements and units which are needed for a given configuration to satisfy user requirements.

List of elements and subassemblies:

- Head controller.

- Electromagnetic head.
- Complete head holder.
- Interface cable.
- Photo detector - optimeter.
- Ink system.
- Ink system with an ink pump.
- Ink Monitoring System (IMS) with cable.
- Bottle of ink.
- Shaft-encoder – conveyor's speed indicator.
- Object holder, the so called gun (used for making overprints manually).
- Additional external alarm indicator.
- Additional external alarm device (with conveyor control and stop indication).
- Code switch.
- Starting kit for RS-232 (or RS-485) serial interface.
- Movable platform with a cable for making overprints manually.
- Bottle of wash-up.
- Wash-up spray.

**NOTE:**

- The above list shall not be considered a specification of accessories (to be) delivered together with a printer or printing system purchased by the user.
- The list of accessories may vary from country to country.

### 2.3.2. Preparatory Steps

In order to prepare a new or transported printer to operation, you should perform the following activities:

1. Remove all parts of the system out of their packing.
2. Place the controller in a room that is free from vibration, shocks, dust, smoke, soil, aggressive or inflammable vapours and gases.

**NOTE:** The room shall meet the following requirements:

**Environmental conditions:** operating temperature from +5°C to +40°C,  
relative humidity up to 90% without condensation.

**Mechanical requirements:** max. vibration 1g at max. frequency 10Hz,  
max. shocks 1g over max. 2ms.

3. Secure the print head holder in a convenient position.

**NOTE:** If the conveyor vibration is too strong, the head holder should be fastened to a stable rack or on a wall that are not part of the conveyor system.

4. Install the print head in a holder. Make sure, however, that the front planes of the head and objects to be labelled are parallel. The electromagnetic print-head can work in any position in space.



- Fix the photo detector on a cradle which has been fastened to the print head, head holder or in any other place convenient for releasing prints. Whereas the slide - in the opening from the side of a coming object.

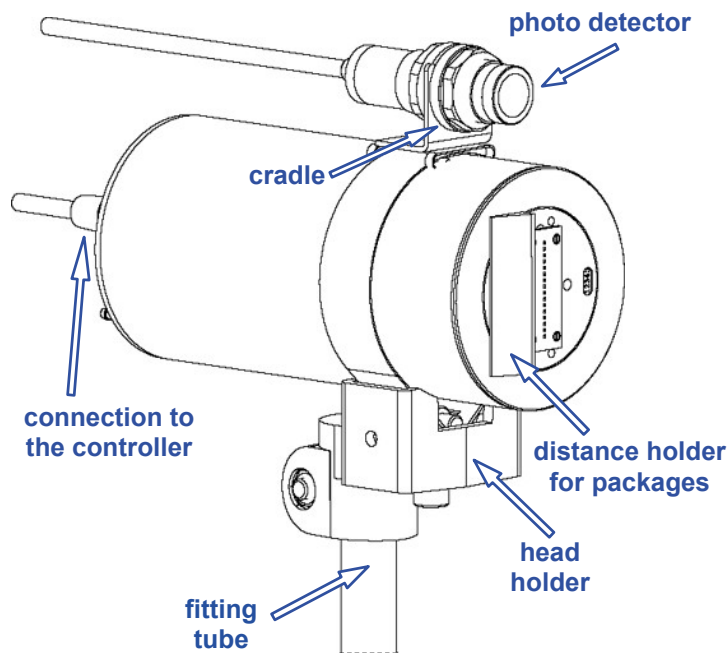

Fig. 2.3.2.1. Fixing a standard electromagnetic head holder to the conveyor

### 2.3.3. Removing Transport Protections

The controller and head are protected against mechanical pressure and the spilling of ink in case the head is tilted or shocked. Therefore some ink system connections are disconnected and protected with plugs, caps or non-return valves. All protection needs to be removed during the installation.

### 2.3.4. Connections

All electrical connections are situated on the right-hand side wall of the controller.

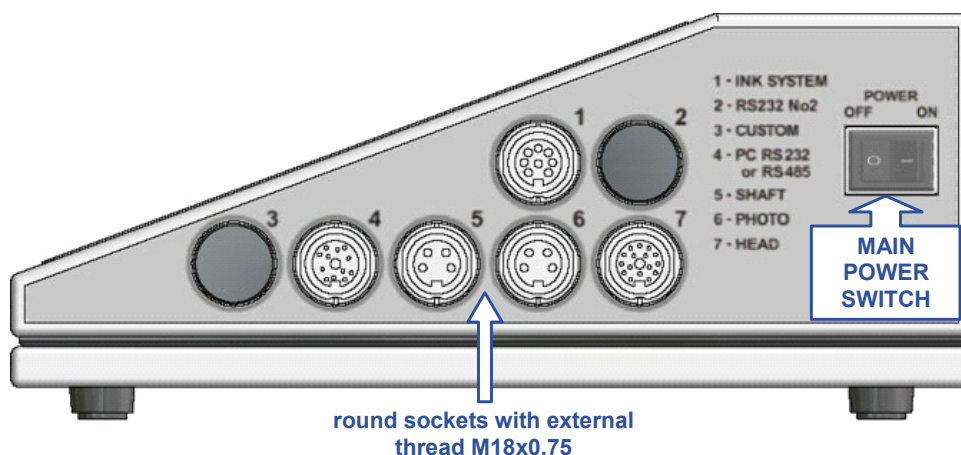

Fig. 2.3.4.1. Controller - view of connection sockets (without plugs)

There can be seven female connectors available on the side wall:

- Ink System socket to connect a cable from the Ink Monitoring System (IMS).
- Serial Interface socket to connect the so called special channel.



3. Custom socket, an option to connect external devices.
4. PC Serial Interface socket to connect a serial interface cable from a PC.
5. Shaft-encoder socket to connect a shaft-encoder's cable.
6. Photo detector socket to connect a photo detector cable.
7. Head socket to connect a head interface cable.

**NOTE:**

- Make sure that protection tabs are matched while plugging in every male connector into the female connector to avoid damaging the contacts.
- Make sure that the external tapped ring on the male connector is tightened up to ensure firm connection between male and female connectors. **Failure to tighten up the ring causes the external cable screen to disconnect from the controller and head body. This damages the electric shock protection and may result in unstable or improper operation of the head.**



### Earthed neutral system

Connect the earthed neutral system as specified in subsection [2.2 Power and Air Supply Requirements](#) with an outlet plug as shown in the drawing. Make sure that the earth contacts of a mains socket are effectively earthed in compliance with the applicable standards.

### Connecting the head

Plug the (16-pin) interface cable carefully into female connector **No 7** on the controller and tighten up the tapped ring. Connect the other end (female connector) of the cable with a similar male connector on the head cover. The controller connection is shown in [Fig. 2.3.4.1](#).

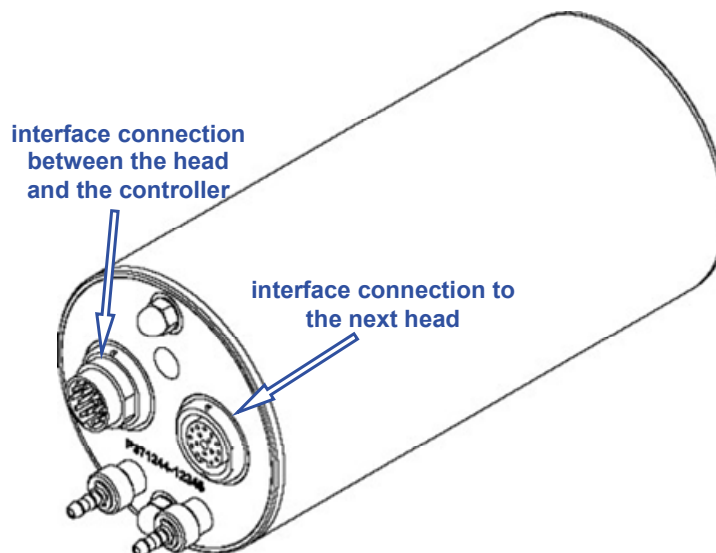

Fig. 2.3.4.2.

If the ink system with an ink pump is used, there is no need to apply a compressor system. Any connections should be made in accordance with the description contained in the document entitled *Ink System with an Ink Pump*.

### Connecting the photo detector

Connect the photo detector, that is an optimeter detecting objects to be labelled, in front of the print head, to female connector **No 6 - PHOTO** (see [Fig. 2.3.4.1](#)).

### ***Connecting the shaft-encoder***

Connect the shaft-encoder, that is a conveyor speed indicator, to female connector **No 5 - SHAFT** (an option for variable-speed conveyors) - see [Fig. 2.3.4.1](#).

### ***Connecting external data transfer devices***

An external device for transferring data (a PC, automatic scales, bar-code reader or other automatic equipment) should be connected to socket **No. 3**.

### ***Connecting the Ink Monitor System - IMS***

Plug in the (8-pin) male connector of the ink monitor system interface cable carefully into female connector **No 1** on the controller and tighten up the tapped ring (for electromagnetic print heads only).

### ***Connecting the head to the ink and compressed air systems***

The ink system for an electromagnetic head is built of the following components (see [Fig. 2.3.4.3](#)):

- A container for a bottle of ink ❶ and grips to fix the container up ❷.
- An Ink Monitoring System ❸.
- A compressed air pressure regulator ❹ with a manometer ❺.
- Pressure tubes of polyethylene for supplying ink and compressed air (the direction in which the medium flows inside the tubes is marked with arrows):
  - a tube, ❻, to supply air under pressure from a compressor system,
  - a tube, ❼, to supply air at a regulator-stabilised pressure,
  - a tube, ❸, to supply ink under pressure from a bottle to the head.
- A bottle of ink ❹.
- A plug to be screwed on the bottle ❿. It contains:
  - a tube with an ink filter at one end (inside the ink bottle),
  - pipe connectors,
  - retaining nuts to secure tubes on the connectors.

In order to connect the ink system to the compressed air system and head to the ink system, follow the steps below:

- a). Supply compressed air out of an external compressor system via a polyethylene tube to the supply air connection at the pressure regulator (marked with an arrow and a letter **P**), as shown in the following picture:
  - slide the retaining nut over the pipe,
  - slide the pipe over the connector,
  - tighten up the retaining nut.

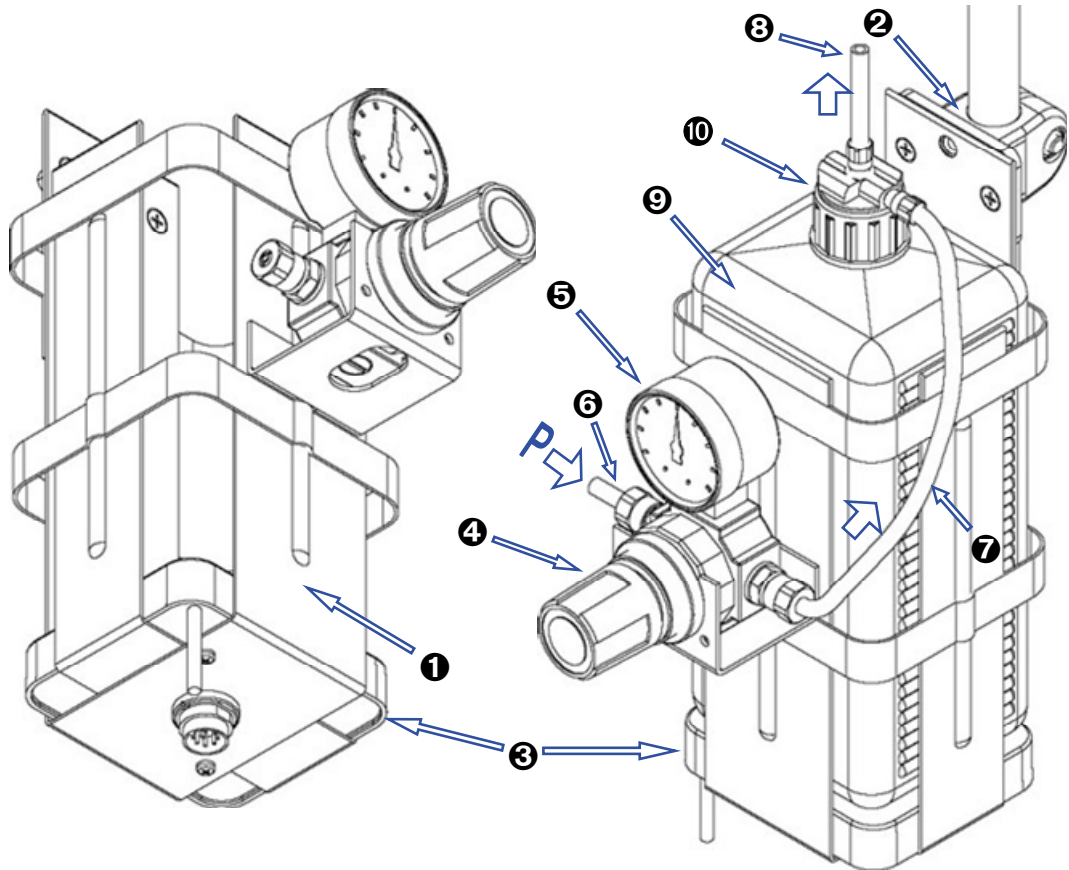

**Fig. 2.3.4.3.**

- b). Connect the pressure regulator outlet and the horizontal bottle-plug coupling with a polyethylene pipe ⑦.
- c). Connect the vertical bottle-plug connector and the non-return valve connector. Insert the valve into the inlet ink connector and tighten up the nut. The non-return valve prevents the ink from leaking out of the head after the pipe has been removed.

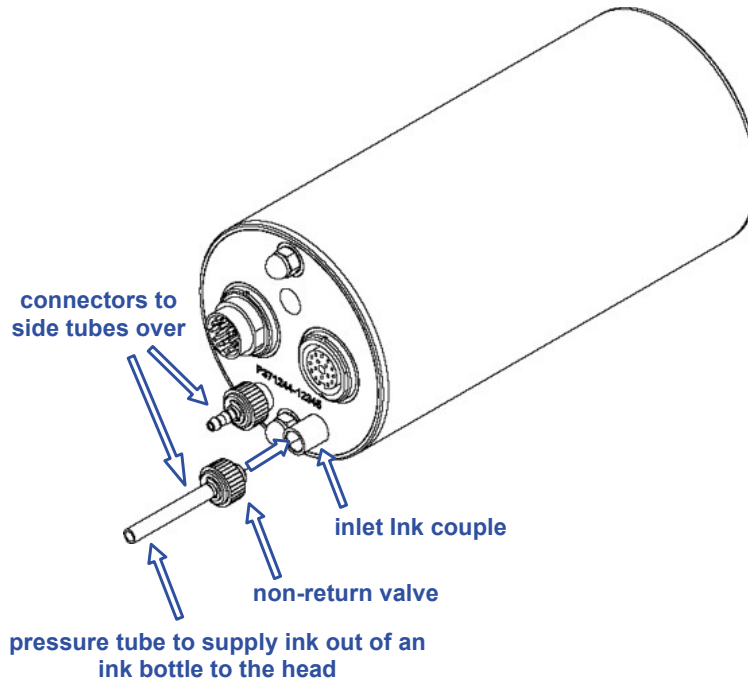

**Fig. 2.3.4.4.**



**NOTE:**

Compressed air supplied to the ink system must meet compressed air specifications given in paragraph **2.2 Power and Air Supply Requirements**.

The rated pressure should be set to the value of **0,04 MPa (0,4 bar)** with a pressure regulator.

The rated pressure depends on nozzle diameter and the number of nozzles in the print head. The nozzle diameter is indicated on the nozzle plate.

For best quality prints on a given surface, the ink pressure inside the head can be slightly adjusted after the primary print parameters (such as height, rate and intensity) have been determined. The adjusted pressure should be within the range from **0.03 MPa (0.3 bar)** to **0.06 MPa (0.6 bar)**.

### **Connecting the head to the pump-based ink system**

A detailed description of how to connect the head to the ink system with an ink pump is given in the document entitled *Ink System with an Ink Pump*.

## **2.3.5. Installing a new Bottle of Ink (or Replacing an Empty One)**



**NOTE:**

- Please note that only the recommended ink type should be used. A possible mistake may result in damage to print head.
- Various types of ink must not be mixed or ink whose usability time prescribed has been exceeded must not be added.

### **Connecting a new ink bottle (or replacing an ink bottle) in the compressor-based system**

In order to install (replace) a bottle of ink, follow the procedure given below:

- a). Depressurise the system and wait until the manometer indicates that the pressure has dropped to zero in the bottle.
- b). Unscrew retaining nuts (❶ and ❷) on the bottle couplings carefully and remove polyethylene tubes ❸ (a tube to supply ink under pressure from the bottle to the head) and ❹ (a tube to supply air at a stabilised pressure from the pressure regulator).

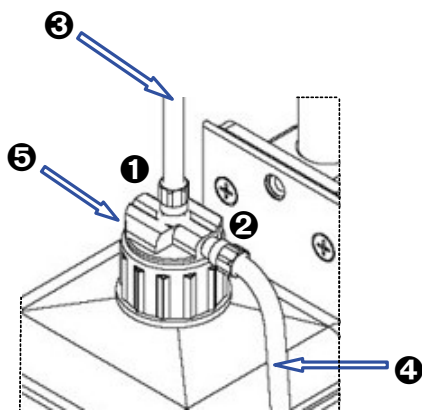

Fig. 2.3.5.1.

- c). Unscrew the plug ⑤ containing a tube and an ink filter at its tip, and remove the plug from the bottle. Check for the ink filter at the tube tip.
- d). Unscrew the plug on a new bottle and remove aluminium foil protection.
- e). Put the new bottle of ink into the container. The new bottle will be accepted after the transponder has been detected and checked (in about 10 seconds) when the printer is on – see a message **BOTTLE ACCEPTED**.
- f). Put the tube with the ink filter at the tip into the bottle and screw on the plug.
- g). Install the tubes onto the couplings and screw on the retaining nuts.
- h). Pressurise the system and adjust the pressure to its rating value.

### Connecting a new ink bottle (or replacing an ink bottle) in the ink system with an ink pump

A detailed description of how to attach a new ink bottle (or replace an old bottle) in the system equipped with an electromagnetic head and the ink system with a pump is given in the document entitled *Ink System with an Ink Pump*.

## 2.4. Removing the Head Cover

The head cover is removed to get access to valves and adjust them.

In order to remove the head cover, follow the procedure given below:

- a). Turn the printer off.
- b). Remove the head from the holder and remove the distance holder for packages ①.
- c). Unscrew two nuts ② at the back of the head and remove shims.
- d). While holding the head cover, press the end face of the head with your thumb until it starts moving out freely (the places where the face should be pressed are shown in Figure 3).
- e). Push the head cover away to ensure that leading bars have moved out of the pipes completely.

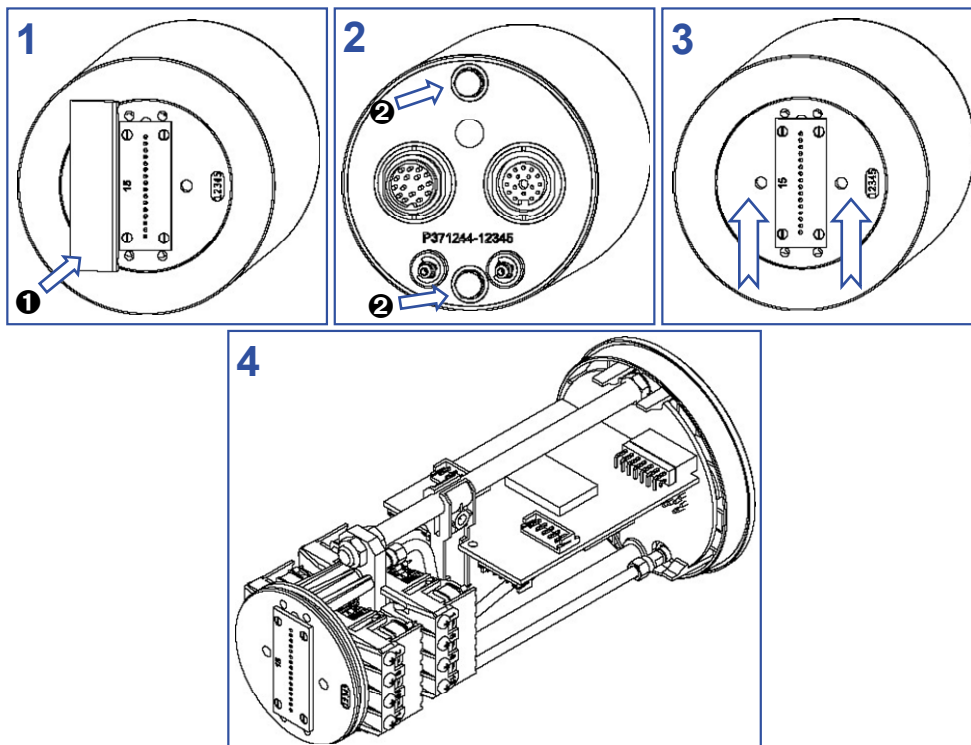

Fig. 2.4.1.

### 3. Starting the Printer

#### 3.1. Switching the Printer On

The **ON/OFF Power switch** is situated on the right side wall of the unit next to the feeder cable. It isolates both power leads from the mains (see [Fig. 2.3.4.1](#)).

If the printer controller, head, and ink system connectors are all connected, it is enough to

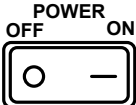
switch the Power switch  to the **ON** position.

With this, a starting procedure is initiated and the following processes are conducted:

1. Power voltages are applied and electronic cards are tested.
2. Terminal display is switched on and the main MENU is displayed.
3. The checking for a bottle of ink is done by detecting the bottle transponder. Ink in the bottle is checked for its usability.

If no errors have occurred, it means that the starting procedure has been completed correctly and the printer is ready for printing.

#### 3.2. Switching the Printer Off

The printer may be switched off at any time (even during the printing). Just switch the Power

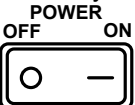
switch  to the **OFF** position.

On switching the unit off protect the heads. You need to do the following:

- depressurise the print head by opening a pressure valve or reducing the pressure to zero with a pressure regulator (if a compressor system is used),
- wash the nozzle plate with solvent.



## 4. Operating the Printer

### 4.1. Operation Panel

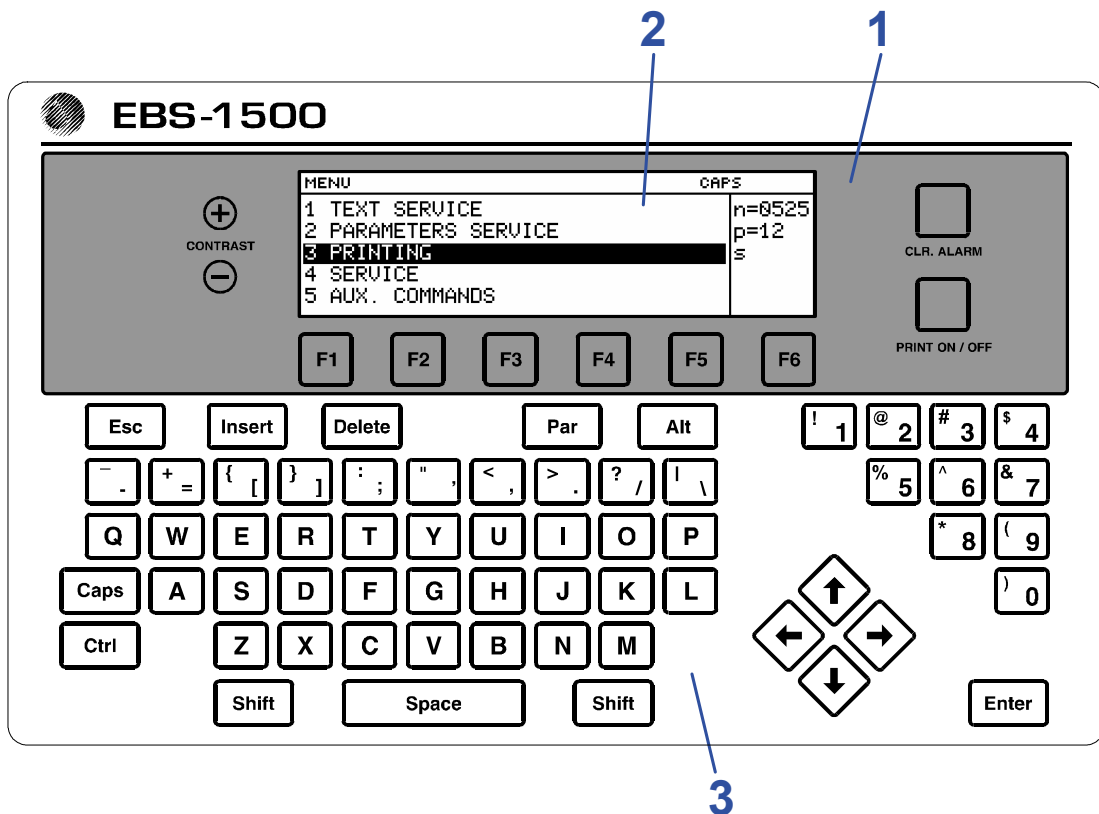
The operation panel enables the printer operator to control and monitor the unit's operation, and initiate actions as might be required in given circumstances. It is also used for performing such basic operations as turning the print mode on or off, locating faults, clearing alarms, etc.



#### 1 The function pad contains the following elements:

- Contrast keys to adjust contrast settings for the LCD display,  
 ⊕ - press to increase the contrast, ⊖ - press to reduce the contrast.
- **F1** **F2** **F3** **F4** **F5** **F6** function keys to define various additional user functions.
- Slate-blue **CLR. ALARM** key (further on marked with a symbol ) to clear alarms.
- Slate-blue **PRINT ON/OFF** key (further on marked with a symbol ) to turn the print mode on or off.



**2** LCD display containing 240x64 pixels<sup>1</sup>. The display area is divided into separate sections called windows.

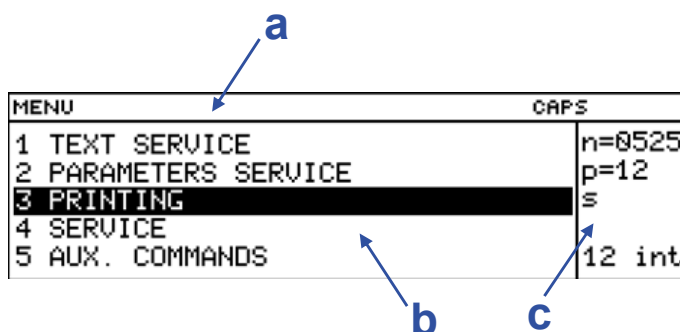

**a** **Terminal status window** it is one line high and shows the following data (from the left-hand side):

- short 12-character messages (e.g. on the editor's pen or a MENU branch name),
- 3-character typing mode (**INS**ert , **OV**eRwrite ),
- setting of the **(CAPS)** key (upper or lower case letters),
- **(SHIFT)** or **(CTRL)** indicators,
- graphical cursor coordinates (while editing graphic files).

**b** **Operating window** it is five lines high; it is the main display window designed to display service **MENU**, parameters and messages, and to edit text files, etc.

**c** **Printer status window** it is on the right of the operating window; it is five lines high and displays data on the print head status in various printer modes - see section **4.3 Print Head Status**.

**3** **Alphanumerical keypad** used to initiate control functions and to type letters or digits (characters).

The keypad contains the following groups of keys for various purposes:

**Control keys**

such as:

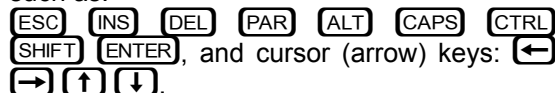

**Number and symbol keys** keys marked with digits **1, 2, ... , 9, 0**.

**Alphabetical and symbol keys** keys marked with letters **A, B, C, ... , Z**, other keys as = [ ] ; ' , . / \ and **(SPACE)**.

All characters specified above are available immediately after the corresponding key has been pressed.

**In order to input symbols that are marked in the top left corner of some keys the (SHIFT) key needs to be pressed first.** This applies to the following symbols: \_ + { } : " < > ? | ! @ # \$ % ^ & \* ( ) .

<sup>1</sup>Pixel - any of the smallest elements that together form a graphical image. It can be on or off.



## 4.2. Operating the Printer with Control MENU









After the printer has been switched on, the control MENU is shown in the operating window on the terminal display. The MENU has a multilevel tree structure. Commands are executed directly at the lowest level. No action is initiated by moving from one menu branch to the other. Only the execution of a command initiates an action such as starting the printing, moving to the word processor, changing parameters, etc.

MENU	CAPS
1 TEXT SERVICE	n=0525
2 PARAMETERS SERVICE	p=12
3 PRINTING	s
4 SERVICE	
5 AUX. COMMANDS	12 int

**Fig. 4.2.1.** Main MENU display on the terminal

The first character (a digit or letter) of every MENU item corresponds to the so called **hot key**. When this key is pressed on the keypad, the cursor bar is positioned on the required item.

The following keys are used to move within the MENU tree:

-  Moves the cursor one menu item upwards.
-  Moves the cursor one menu item downwards.
-  or  Move the cursor to the first item.
-  or  Move the cursor bar to the last item.
-  Moves to a lower level in the MENU (to the next MENU branch) or confirms the selection.
-  Moves to a higher level in the MENU or cancels the selection. When you press the  key several times, it brings you back to the main MENU.

**NOTE:**

After a command has been confirmed with the  key, you may not be able to cancel it. Some commands are executed immediately.



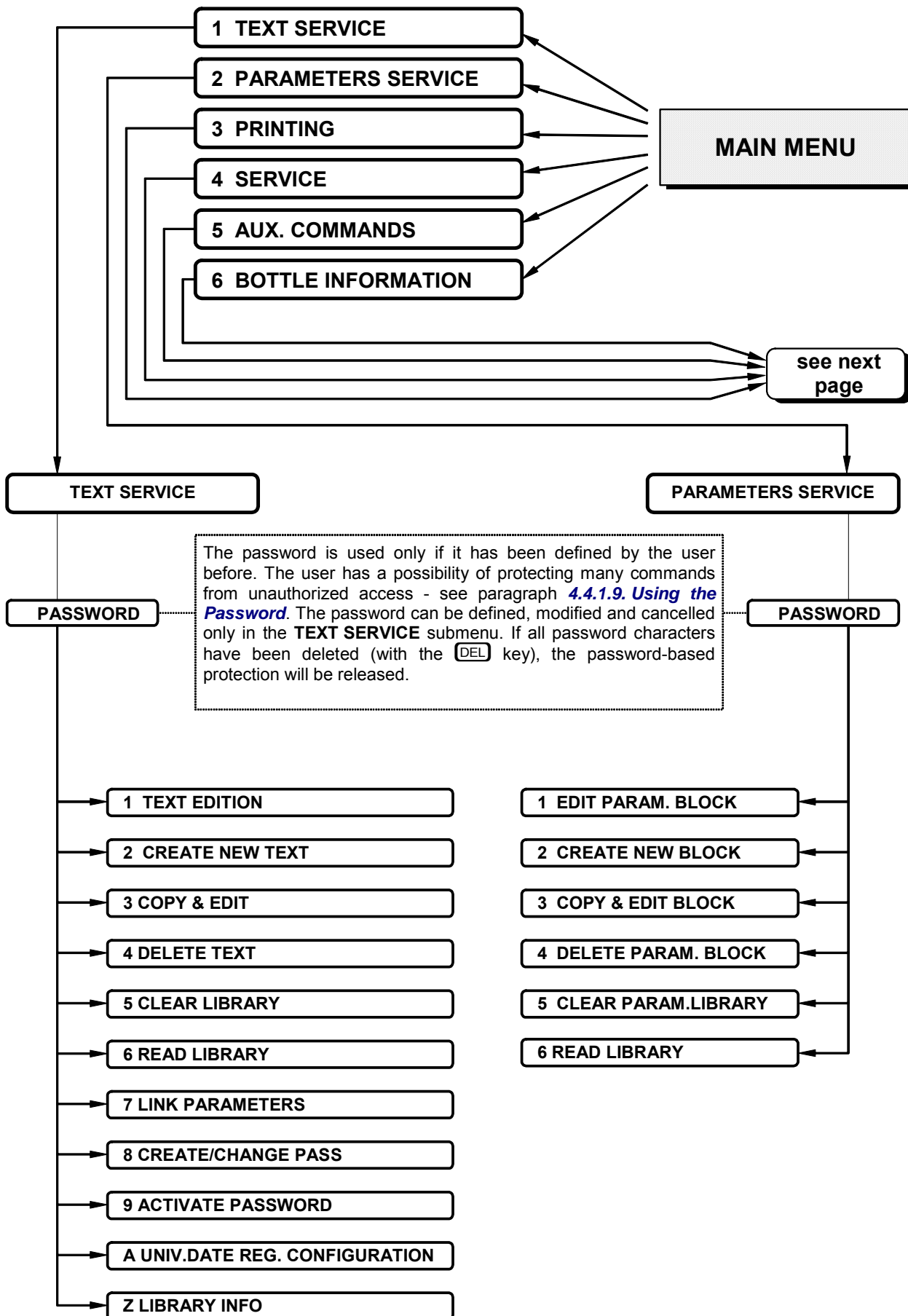

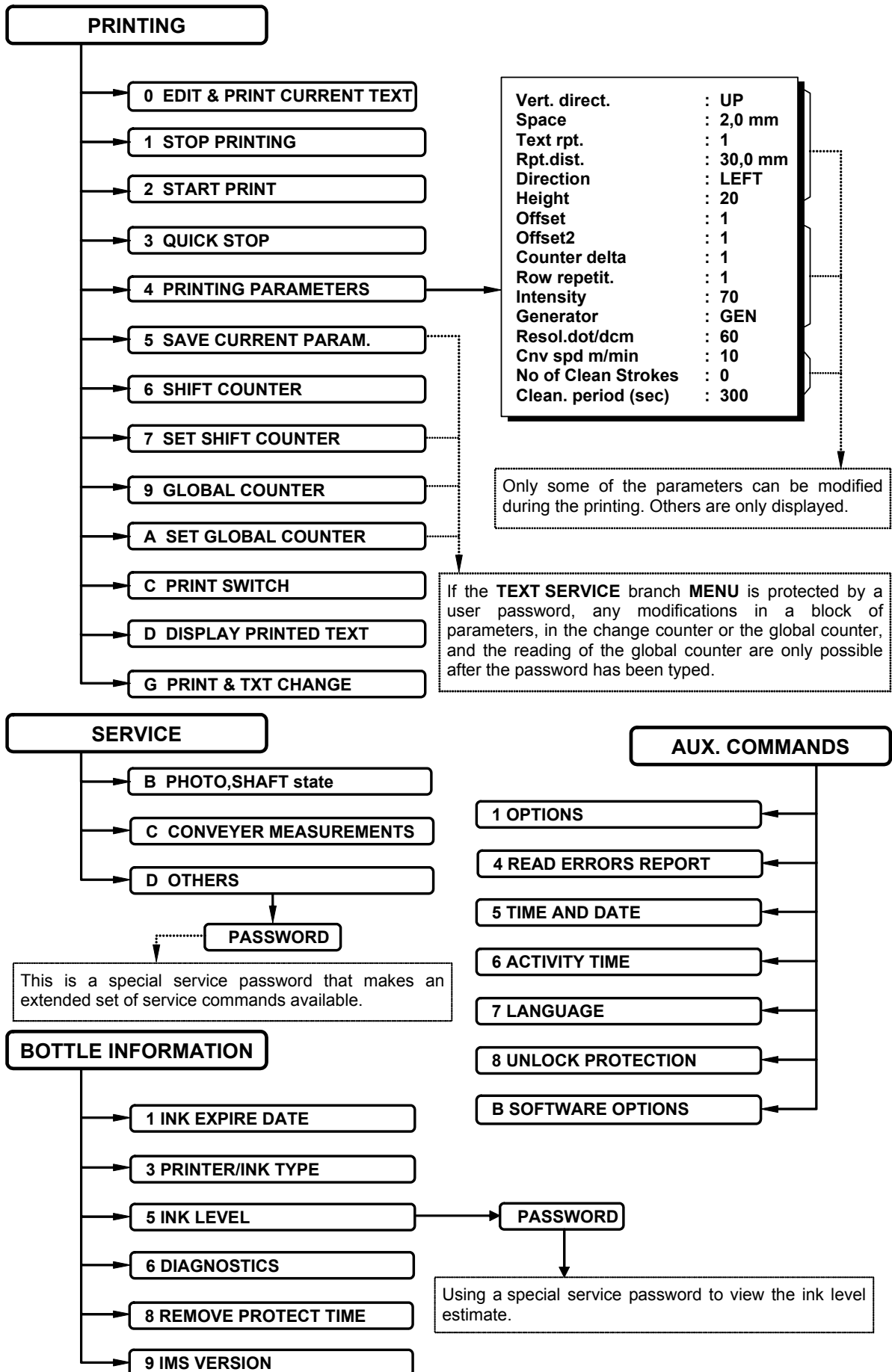

### 4.3. Print Head Status

There are several modes of the print head operation. The number and types of modes depend on the type of head that is connected to the controller. The mode and relevant parameters are described by **the print head status**. The status is a set of print head parameters shown in the printer status window on the terminal display.

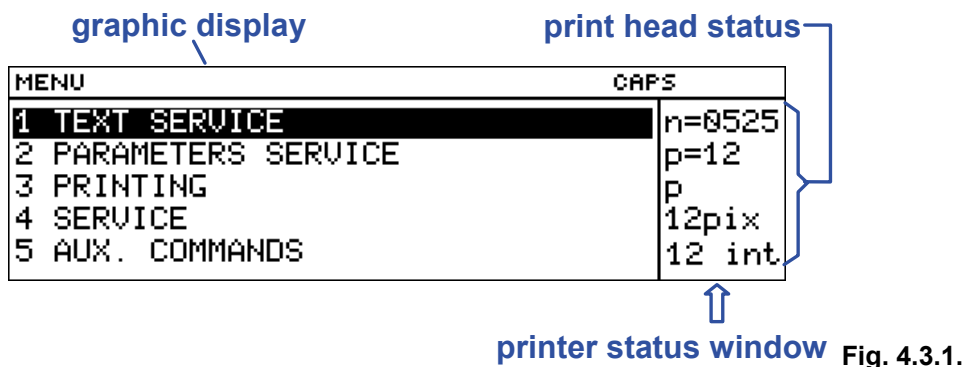

Characters shown in the status window have the following meaning:

1. The serial number of the printer is displayed on the first line. The characters „n=“ are followed by four digits. They are the last digits of the printer controller number that is stamped on the back wall of the housing (in the name plate window).
2. On the second line, the characters „p=“ are followed by a number that is the maximum height of the overprint (in other words, it is the number of independent nozzles within the print head). This value is read from the head each time the printer controller is started and it remains unchanged during operation.
3. The third line (one character) shows the print head status. The print head can be in one of the following modes:
  - s** (**stop**) the print head is ready to start the printing,
  - p** (**print**) the print head is performing the printing operation, which means the **START PRINT** or **PRINT SWITCH** commands have been selected
4. After the **START PRINT** command has been selected, another number is displayed on the fourth line (ending in „pix“). The number indicates the maximum amount of dots along the vertical direction (5, 7, 12, 16, 25, 32, 64 dots) within the current overprint. In other words, it is the actual overprint height.
5. The fifth line contains additional data. The individual characters have the following meaning:
  - The first characters define the total number of nozzles (e.g. 5, 7, 12, 16, 25, 32, 64) in the head. This parameter is updated on an on-going basis and its value should be the same as the maximum row height displayed on the second line of the status block. A difference between these values may show that some irregularities have occurred.
  - The other part of the line shows the head subtype. This parameter depends on the method of how print intensity is controlled and is also updated on an on-going basis.

**NOTE:**

- If the function key **F4** is pressed during the printing (i.e. following the **START PRINT** command), the name of a text file being printed is displayed (for about 1 second) rather than the text height. If the **F4** key is pressed several times, the file name is displayed for a longer time.
- If the user is allowed to use the printer for a limited period of time (under a separate contract), the first status line is displayed in inversion (light character on the dark background, e.g. **4:33**). The printer stops operating automatically after the defined time limit has elapsed.



## 4.4. Controlling the Printer

### 4.4.1. Text Files

#### 4.4.1.1. Introduction to Text Files

Any text file operations are grouped in the MENU branch **TEXT SERVICE**.

**NOTE:**

If the MENU branch **TEXT SERVICE** is protected with a user password, the operator is asked to type the password before the contents of the submenu are displayed. Further details on the user password are given in section [4.4.1.9 Using the Password](#).



Text files are stored in a library in the printer memory. Each text file is identified by a name of up to 8 characters. The name can be built up of alphabetical (capital and small) letters, digits and some symbols except spaces, dots or characters such as: \ / : \* ? " < > | e.g. **12345678**, **AB#%CD&**, **WEIGHT-5**, **JUICES**, **DATEtime**, **Q1**, **star@ice**, etc. Text names and the arrangement of text names in the library enable the user to move through text files easily and find the right files without any problems.

Every text file in the library can have the **read only** attribute assigned to it in order to prevent it from being deleted or modified by an unauthorised person. The **read only** attribute can be assigned to/removed from a single text file or all text files stored in the library. For more information refer to paragraph [4.4.1.7 Accessing the File Library](#).

Some commands show the library contents in alphabetical order in the operating window of the display.

			CAPS
12345678	ABCD....	DATE....	n=0525
EX_DATE.	GROSS-WT	ICEcream	p=12
LOGO....	<b>NET-WT..</b>	NUMBER-1	s
NUMBER-2	NUMBER-3	QWERTY-1	
Shift-No	TIME....	WEIGHT..	12 int

The following facilities enable the user to move along the file directory freely:

- the **←** **→** **↓** **↑** keys to move the cursor from one name to the other,
- the leading character (a letter or digit) to move the cursor to the first name that starts with this character,
- the **SHIFT** **←** (**HOME**) or **SHIFT** **↑** keys to move the cursor to the first name in the library,
- the **SHIFT** **→** (**END**) or **SHIFT** **↓** key to move the cursor to the last name in the library.



**NOTE:**  
 If the printer memory is overflowed (with a lot of or very long text files or parameter blocks), the file names may not be arranged in alphabetical order and some facilities may not be effective.

The files can be divided into two groups:

- **simple text files,**
- **complex text files.**

The simple text files cover the following types of texts:

- **a string of ASCII characters,**
- **a graphical image,**
- **a bar code,**
- **a subfile** (another text called by its name).

There is often a need to merge several text files into a more **complex text**. In every case you can create a complex text file from the very beginning or merge text files (hereinafter called the **subtexts**) that already exist in the library, merging them by name. A file created by merging may be used as part of another file.



**NOTE:**

- **Once created, a text file remains in the printer memory even if the power supply has been switched off. A file can be deleted from the library.**
- The maximal file length is restricted by the volume of the printer memory available.
- Up to 6 special registers can be used in a complex text file (see below).

### WORD PROCESSOR – A Description of Control Keys

← → ↑ ↓	To navigate within a given subfile or between text files.		
[SHIFT] ← →	To move the cursor to the first or to the last character in an ASCII subfile		
[SHIFT] ↑ ↓	To move the entire subfile by one pixel (dot) upwards or downwards.		
[CTRL] ← → ↑ ↓	To create a new subfile in a given position in relation to the current subfile.		
[INS]	To switch between two character insertion modes: <b>INS</b> ert/ <b>OV</b> erwrite.		
[DEL]	To delete a character at the cursor position in a subfile.		
[ALT]	<p>To switch between national characters on the keypad. The selection is indicated in the terminal status window, for example <b>K:POL</b>.</p> <table style="width: 100%; border: none;"> <tr> <td style="width: 50%; vertical-align: top;"> <p><b>German characters</b>                      indication: <b>K:GER</b></p> <p>character <b>ä</b> corresponds to <b>a</b></p> <p style="padding-left: 40px;">ö                    o</p> <p style="padding-left: 40px;">ß                    s</p> <p style="padding-left: 40px;">ü                    u</p> <p style="padding-left: 40px;">Ä                    A</p> <p style="padding-left: 40px;">Ö                    O</p> <p style="padding-left: 40px;">ß                    S</p> <p style="padding-left: 40px;">Ü                    U</p> </td> <td style="width: 50%; vertical-align: top;"> <p><b>Polish characters</b>                      indication: <b>K:POL</b></p> <p>characters <b>ą</b> correspond to <b>aA</b></p> <p style="padding-left: 40px;">ć                    cC</p> <p style="padding-left: 40px;">ę                    eE</p> <p style="padding-left: 40px;">ł                    lL</p> <p style="padding-left: 40px;">ń                    nN</p> <p style="padding-left: 40px;">ó                    oO</p> <p style="padding-left: 40px;">ś                    sS</p> <p style="padding-left: 40px;">ź                    xX</p> <p style="padding-left: 40px;">ż                    zZ</p> </td> </tr> </table>	<p><b>German characters</b>                      indication: <b>K:GER</b></p> <p>character <b>ä</b> corresponds to <b>a</b></p> <p style="padding-left: 40px;">ö                    o</p> <p style="padding-left: 40px;">ß                    s</p> <p style="padding-left: 40px;">ü                    u</p> <p style="padding-left: 40px;">Ä                    A</p> <p style="padding-left: 40px;">Ö                    O</p> <p style="padding-left: 40px;">ß                    S</p> <p style="padding-left: 40px;">Ü                    U</p>	<p><b>Polish characters</b>                      indication: <b>K:POL</b></p> <p>characters <b>ą</b> correspond to <b>aA</b></p> <p style="padding-left: 40px;">ć                    cC</p> <p style="padding-left: 40px;">ę                    eE</p> <p style="padding-left: 40px;">ł                    lL</p> <p style="padding-left: 40px;">ń                    nN</p> <p style="padding-left: 40px;">ó                    oO</p> <p style="padding-left: 40px;">ś                    sS</p> <p style="padding-left: 40px;">ź                    xX</p> <p style="padding-left: 40px;">ż                    zZ</p>
<p><b>German characters</b>                      indication: <b>K:GER</b></p> <p>character <b>ä</b> corresponds to <b>a</b></p> <p style="padding-left: 40px;">ö                    o</p> <p style="padding-left: 40px;">ß                    s</p> <p style="padding-left: 40px;">ü                    u</p> <p style="padding-left: 40px;">Ä                    A</p> <p style="padding-left: 40px;">Ö                    O</p> <p style="padding-left: 40px;">ß                    S</p> <p style="padding-left: 40px;">Ü                    U</p>	<p><b>Polish characters</b>                      indication: <b>K:POL</b></p> <p>characters <b>ą</b> correspond to <b>aA</b></p> <p style="padding-left: 40px;">ć                    cC</p> <p style="padding-left: 40px;">ę                    eE</p> <p style="padding-left: 40px;">ł                    lL</p> <p style="padding-left: 40px;">ń                    nN</p> <p style="padding-left: 40px;">ó                    oO</p> <p style="padding-left: 40px;">ś                    sS</p> <p style="padding-left: 40px;">ź                    xX</p> <p style="padding-left: 40px;">ż                    zZ</p>		

<b>PAR</b>	To edit (modify) parameters of a subfile and to change the subfile type.
<b>CTRL DEL</b>	To delete the entire subfile.
<b>CTRL ENTER</b>	To edit a graphics subfile.
<b>ESC</b>	To cancel the edition (modification) of a current text.
<b>ENTER</b>	To indicated the end of the edition (save the file in the library).
<b>CTRL Q</b>	To switch between two space display modes <sup>2</sup> . Spaces can be displayed as <code>␣</code> (by default) or as blanks. Spaces are always printed as blanks no matter which display mode is active.

#### 4.4.1.2. Opening and Editing a New File

In the main MENU select the **TEXT SERVICE** item and then the **CREATE NEW TEXT** item, type in a subfile name consisting of up to eight characters and confirm.

**NOTE:**  
 If the file name exists in the library, the file appears on the terminal and can be edited.

The word processor starts and various types of simple and complex files can be generated. The word processor opens an **ASCII** file, with the letter height set to the highest value by default. The file contains one space. Now you can use the keypad to input a text to be printed. A description of control keys is given in section **4.4.1.1 Introduction to Text Files** paragraph **WORD PROCESSOR – A Description of Control Keys**.

You can modify text file attributes or type by entering the subfile menu with the **PAR** key.

The first item in the subfile menu is **Type**. All subfile types available together with parameters and default settings are described later on in this document.

The setting of each of the parameters can be modified with the **→** and **←** keys. The setting of a numerical parameter can also be input directly from the keypad and confirmed with the **ENTER** key.

For various simple text files (subfiles), subfiles are created in different ways. In the following paragraphs you will find a description of how to create and edit simple files of various types.

On selecting the subfile type, setting file parameters and typing the file contents, the text file needs confirming or cancelling.

#### **Subfile type: TEKST – ASCII characters**

This simple text file (subfile) is a set of alphabetical characters. The standard word processor offers the Latin alphabet as ASCII characters.

The characters are coded with matrices (or character generators), whose examples are given below :

<b>MATRIX</b>	<b>EXAMPLE</b>
<b>Latin 5x5</b> pixels	ABCDEFGHI1234567890
<b>Latin 7x5</b> pixels	ABCD12345ÄÖßÜACEŁNOSZZÄÆΘÑäöβüaçęłńóśźzøñ
<b>Latin 9x5</b> pixels	ABCD12345ÄÖßÜACEŁNOSZZÄÆΘÑabcdäöβüaçęłńóśźzæ.ñ
<b>Latin 16x10</b> pixels	12345ÄÖßÜACEŁNOSZZÄÆΘÑäöβüęłńóśźñ

<sup>2</sup>Space – a blank distance between characters; it is inserted with the **SPACE** key on the terminal.





When the **PAR** key is pressed in the word processor, parameter menu is displayed for your subfile. The parameters have the following meaning:

PARAMETER	DESCRIPTION AND SETTINGS	DEFAULT
<b>Type</b> :	Subfile type. Any parameters shown below are typical for a <b>Text</b> subfile. <b>subText, Graphic, Barcode, Ins. text</b>	<b>Text</b>
<b>Char. set</b> :	Character generators for the above mentioned matrices (number and types of generators installed in the printer depend on the type of print head used and user requirements): <b>Latin 5x5, Latin 7x5, Latin 9x5, Latin 16x10, Latin 25x15, Latin 32x18, Latin 21x15, Cyrylic 25x19, Cyril.16x10, Cyrylic 7x6, Arab.Dg.7x5, Lat_5x5_, Spec 25, Spec 16, Spec 7, Latin 9x7, Latin 11x8, Latin 16x14, Latin 64, Latin</b>	As high as possible
<b>Typeface</b> :	Files can be printed boldface or the printing of every vertical row will be repeated n times ( $n=2\div 15$ ). <b>Bold, Normal, Length *2, .... , Length *15</b>	<b>Normal</b>
<b>Distance</b> :	Distance (a number of dots) between characters in vertical rows. <b>0, 1, 2, .... , 15</b>	<b>2</b>
<b>Rotation</b> :	Every character within a subfile can be rotated. <b>None, Right, Upside down, Left</b>	<b>None</b>
<b>Spec.reg.</b> :	The so called special register can also be used as a subfile. Its contents can vary during the printing - see section <b>4.4.1.10 Using Special Registers</b> . <b>None, Up counter, Down count., Time, Date, Spec. chan., Univ.count., Univ. date, Date+offs., Date+offs.2</b>	<b>None</b>
<b>Front dis</b> :	Leading spacing before a subtext, given as a number of vertical rows (dots). <b>0, 1, 2, 3, .... , 5000</b>	<b>0</b>
<b>Back dist</b> :	Ending spacing behind a subtext, given as a number of vertical rows (dots). <b>0, 1, 2, 3, .... , 5000</b>	<b>0</b>

**NOTE:**

- Subfile parameters can be changed at any time during the edition (by pressing the **PAR** key).
- Subfile type can be changed at any time during the edition (by pressing the **PAR** key). When the type (and parameters) have been changed and confirmed, the previous subfile contents are erased.

**Subfile type: GRAPHICS**

A **GRAPHICS** subfile is a block of pixels (on the display) or dots (on the overprint) that are set/erased separately.

When the **PAR** key is pressed in the word processor, parameter menu is displayed for your subfile. The parameters have the following meaning:

PARAMETER	DESCRIPTION AND SETTINGS	DEFAULT
<b>Type</b> :	Subfile type. Any parameters shown below are typical for a <b>Graphics</b> subfile. <b>Graphic, Barcode, Ins. text, subText</b>	<b>Text</b>
<b>Height</b> :	The maximum height (number of pixels) of a graphic block equals the maximum height <b>Hmax</b> of a printable vertical row. <b>1, 2, 3, .... , Hmax</b>	<b>Hmax</b>
<b>Length</b> :	Expected length (number of pixels) of a graphic block. <b>1, 2, 3, .... , 32767</b>	As set
<b>Front dis</b> :	Blank space (number of vertical rows) before a graphic block. <b>0, 1, 2, 3, .... , 5000</b>	<b>0</b>
<b>Back dist</b> :	Blank space (number of vertical rows) after a graphic block. <b>0, 1, 2, 3, .... , 5000</b>	<b>0</b>



**NOTE:**

- Subfile parameters can be changed at any time during the edition of a **Graphic** (by pressing the **PAR** key).
- After the edition of a graphic block has been completed, empty vertical rows on the right of the last non-blank row are deleted automatically. Therefore the block length changes and differs from the original setting.

By pressing the **CTRL****ENTER** keys you will move to the word processor, where every pixel can be inserted/erased. The image is magnified four times to make individual pixels more visible on the display. The graphic cursor coordinates are shown in the status window on the terminal display. A reference point is for them the top left corner of the graphic block.

**X:** horizontal coordinate      **Y:** vertical coordinate.

**GRAPHIC PROCESSOR – A description of function keys**

<b>SPACE</b>	To show in inversion (off/on) a point indicated by the cursor.
<b>ALT</b>	To switch between the editor pen modes: <b>UP / SET / CLEAR</b> . <b>UP</b> lift up the pen, <b>SET</b> set the pen in the <b>&gt;write&lt;</b> mode, <b>CLEAR</b> set the pen in the <b>&gt;erase&lt;</b> mode. The pen status is displayed in the terminal status window.
	To invert (enable/disable) every element of a graphic subfile irrespective of the pen state defined with the <b>ALT</b> key.
← → ↑ ↓	To move the cursor right, left, up or down according to the pen mode. If the cursor is moved right, beyond the length limit, new vertical rows are inserted and the subfile length is modified.
<b>SHIFT</b> ← → ↑ ↓	To move the cursor by 8 dots in the direction indicated by the arrow.
<b>INS</b>	To insert an empty vertical row and move the following rows by one row to the right.



<b>DEL</b>	To delete the vertical row where the cursor is and move the rows further on by one dot to the left.
<b>SHIFT INS</b>	To insert one blank horizontal row and move the below rows by one dot down (with no change in the subfile height).
<b>SHIFT DEL</b>	To delete the horizontal row where the cursor is and move the downward rows by one dot up (with no change in the subfile height).
<b>ENTER</b>	To confirm modifications and return to the word processor.
<b>ESC</b>	To cancel modifications and return to the word processor.

### **Subfile type: BAR CODE**

A **BAR CODE** subfile is a bar-code block. The processor offers an option to create various barcodes defined by the applicable standards.

When the **PAR** key is pressed in the word processor, parameter menu is displayed for your subfile. The parameters have the following meaning:

PARAMETER	DESCRIPTION AND SETTINGS	DEFAULT
<b>Type</b> :	Subfile type. Any parameters shown below are typical for a <b>Bar Code</b> subfile. <b>Barcode, Ins. text, subText, Graphic</b>	<b>Text</b>
<b>Code</b> :	Bar code type: <b>Datalogic, Matrix, 2/5 5 Bars, Interleaved, Code 39, EAN-8, EAN-13, UPC-A, Kod 128, EAN-128, Kod 128B, ITF8, ITF14</b>	<b>Datalogic</b>
<b>Contents</b> :	Information stored in the bar code. It shall follow bar-code specific rules. e.g. <b>590069701766</b> for the <b>EAN-13</b> bar code For the <b>EAN-8</b> code input 7 characters (the 8 <sup>th</sup> one is calculated automatically). For <b>EAN-13</b> input 12 characters (the 13 <sup>th</sup> one is calculated automatically).	No value
<b>Height</b> :	The maximum bar height (a number of pixels) equals the maximum height of <b>Hmax</b> of a printable vertical row. <b>1, 2, 3, ...., Hmax</b> <b>10, 11, 12, ...., Hmax</b> for <b>EAN-8</b> and <b>EAN-13</b>	<b>Hmax</b>
<b>Elongat.X</b> :	Defines how many times the printing of a vertical row is repeated. It is used to scale the width of a bar code block. <b>1, 2, 3, ...., 16</b>	<b>1</b>
<b>Corrector:</b>	Adjustment of the code bar thickness to space between bars ratio. It is used for highly hygroscopic surfaces. <b>-3, -2, -1, 0</b>	<b>0</b>
<b>Spec.reg.</b> :	A bar code can be the so called special register (counter) - see section <b>4.4.1.10 Using Special Registers – Object Counters</b> . <b>None, Up counter, Down count. Spec. chan.</b>	<b>None</b>

<b>Front dis</b> :	A blank space (a number of vertical rows-dots) before a code block. <b>0, 1, 2, 3, .... , 5000</b>	<b>0</b>
<b>Back dist</b> :	A blank space (a number of vertical rows-dots) after a bar code block. <b>0, 1, 2, 3, .... , 5000</b>	<b>0</b>
<b>Signature</b> :	An indication, whether a numerical caption is to be added beneath the bar code. <b>5 pix, 7 pix, NO</b> The numerical caption is added only when <u>the bar code height exceeds 12 pixels.</u> 	<b>5 pix</b>
<b>Sign.dist</b> :	A blank space (a number of vertical rows-dots) before a code block. <b>1 pix, 2 pix</b>	<b>1 pix</b>
<b>Inversion</b> :	An indication, whether a bar code is to be printed in inverted colours. <b>YES, NO</b> When a bar code is printed in inversion, no bars are printed but only spaces are printed instead, and filled-in fields are added before and after the bar code. The inversion is used to print bar codes with white ink on a black background.  The <b>EAN-13</b> bar code not in inversion, i.e. <b>Inversion=NO</b> (32pix.). The <b>EAN-13</b> bar code in inversion, i.e. <b>Inversion=YES</b> (32pix.).	<b>NO</b>



**NOTE:**

- Subfile parameters can be changed at any time during the edition of a **Barcode** subfile (by pressing the **PAR** key).
- In some cases parameter ranges may be reduced to ensure the bar code standards are met and editing rules are followed.

**Subfile type: Text file Name**

Every file stored under its name in the library can be merged into another file as 'a subfile called by its name'. The **TEXT FILE NAME** subfile is a simple or complex subfile. It cannot be edited inside the file it has been merged into. It can only be edited as a separate library file.

When the **[PAR]** key is pressed in the word processor, parameter menu is displayed for your subfile. The parameters have the following meaning:

PARAMETER	DESCRIPTION AND SETTINGS	DEFAULT
<b>Type</b> :	Subfile type. Any parameters shown below are typical for a <b>Ins. text</b> subfile <b>Ins. text, subText, Graphic, Barcode</b>	<b>Text</b>
<b>Text name</b> :	Specify a name of a library-stored file. The file name can also be selected from the library by pressing the <b>[ALT]</b> key.	No values
<b>Front dis</b> :	A blank space (a number of vertical rows) before a subfile that is called by its name. <b>0, 1, 2, 3, .... , 5000</b>	<b>0</b>
<b>Back dist</b> :	A blank space (a number of vertical rows) after a subfile that is called by its name. <b>0, 1, 2, 3, .... , 5000</b>	<b>0</b>

**NOTE:**  
 Subfile parameters can be changed during the edition of **Ins. text** subfile at any time (by pressing the **[PAR]** key).



#### 4.4.1.3. Editing an Existing Subfile

In the main MENU select the **TEXT SERVICE** item and then the **TEXT EDITION** item.

After a text file has been selected from the library, a word processor starts running and you can edit the text file or its parameters.

A description of control keys used by the processors is given in section [4.4.1.1 Introduction to Text Files](#), paragraph [WORD PROCESSOR – A Description of Control Keys](#). For how to edit individual subfile types see section [4.4.1.2 Opening and Editing a New File](#).

After the edition has been completed, confirm or cancel all modifications.

#### 4.4.1.4. Copying and Editing a Text file

You can create a new text file by copying an existing file from the library and saving it with another name. In the main MENU select the **TEXT SERVICE** item and then the **COPY & EDIT BLOCK** item.

The display shows the text file library from which you should select the name of a text file to be copied (see also section [4.4.1.1 Introduction to Text Files](#)).

Then input an up to eight-character name for the new file that has just been copied.

If the new name exists in the library, the following message is displayed: **\*TEXT EXISTS\***.

After the file name has been typed, the word processor starts. The file is displayed on the terminal. It can be edited as described in section [4.4.1.3 Editing an Existing Subfile](#).

#### 4.4.1.5. Deleting a Text file

In the main MENU select the **TEXT SERVICE** item and then the **DELETE TEXT** item.

The display shows the text file library from which you should select the name of a text file to be deleted and confirm the selection (see also section [4.4.1.1 Introduction to Text Files](#)).

When confirmed, the text file is deleted irretrievably.

#### 4.4.1.6. Deleting the File Library

Deleting the library means deleting all text files that are stored in the printer's memory. In the main MENU select the **TEXT SERVICE** item and then the **CLEAR LIBRARY** item.

When confirmed, the text files are deleted irretrievably.















#### 4.4.1.7. Accessing the File Library

Reviewing the file library means reviewing all text files that are stored in the printer's memory, together with parameter blocks assigned to them. In the main MENU select the **TEXT SERVICE** item and then the **READ LIBRARY** item.

TEXT:PARAMS	CAPS
+!TEXT-5.:!__PAR__	n=0525
12345678:.....	p=12
+WEIGHT.:PAR-1..	s
TIME....:TIME_P..	12 int

File and parameter-block names are displayed in the operating window in alphabetical order and separated with ":". The window can be used not only to view text files but also to separate the parameter block from a text file selected and to assign/remove the **read only attribute** in order to prevent the text files from being deleted or modified by unauthorised persons. The text files with the **read only** attribute are marked with a "+" sign that precedes the file names. The text file attribute markers ("+" or "space") are also displayed with the **TEXT EDITION** and **COPY & EDIT** commands but they cannot be modified with these commands.

The following functions are available while the text files library is viewed:

Terminal key	Function
 	To display the next/previous screen showing text file names.
An alphabetical or numerical key	To display the text file names starting from the first name that begins with a given character.
  (HOME) lub  	To place the cursor on the first name in the library.
  (END) lub  	To place the cursor on the last name in the library.
	To assign/remove the <b>read only</b> attribute to/from a selected text file. The operation is available only when the service password is enabled. If the password level is too low, you will be asked for a password when you make an attempt to change the attribute.
	To assign the <b>read only</b> attribute to every text in the library. The option is available only when the service password is enabled. If the password level is too low, you will be asked for a password when you make an attempt to change the attribute.
	To remove the <b>read only</b> attribute from every text in the library. The option is available only when the service password is enabled. If the password level is too low, you will be asked for a password when you make an attempt to change the attribute.
	To detach the parameter block from the text file previously selected with the cursor.

**NOTE:** If no text files are defined in the library, the command is ignored.

#### 4.4.1.8. Linking File Names with Parameter-block Names

Certain print parameters need to be set during the printing (see section [4.4.3.4 Print Parameters](#)). When you change the text to be printed (e.g. as the line of products to be labelled changes), the parameters need to be adjusted accordingly. Therefore it would be advisable to develop a tool that might enable you to do the following:

- Store print parameters for a given text file,
- Link the parameters stored with the text file to be printed,
- Set all parameters for the text file automatically just before the printing, after the print command has been chosen.

A solution to meet the above requirements is offered by **EBS** printers. Every text file (that is stored in the library) can be linked with a parameter block and such a pair can be stored in the file library. To do this, follow the procedure below:

In the main MENU select the **TEXT SERVICE** item and then the **LINK PARAMETERS** item.

The display shows the text file library from which you should select a text file name (see also section [4.4.1.1 Introduction to Text Files](#)). Then the parameter block library is displayed, from which you should select a parameter block name.

Now the text file name is linked with the corresponding parameter-block name and the relevant information remains in the printer memory even if the power supply is switched off.

For how to detach the parameter block from the a selected text file see paragraph [4.4.1.7 Accessing the File Library](#).

#### 4.4.1.9. Using the Password

You can secure access to the following commands that are called *protected commands* further on:

- all commands in the menu branch **TEXT SERVICE**,
- all commands in the menu branch **PARAMETERS SERVICE**,
- commands in the menu branch **PRINTING**, such as:
  - **SAVE CURRENT PARAM.**,
  - **SET SHIFT COUNTER**,
  - **GLOBAL COUNTER**,
  - **SET GLOBAL COUNTER**.

The objective is to protect text files, parameter blocks and the object counter against accidental or deliberate access by unauthorised persons.

This security feature is implemented by defining a password and enabling the password. Any access to the secured MENU commands is possible only after the password has been typed in. When the right password has been typed, the commands previously unavailable will become available until the password function is enabled again or the printer is turned off. When the password is defined, the password function is enabled automatically after the unit has been switch on.

#### **Defining a User Password**

In the main MENU select the **TEXT SERVICE** item and then the **CREATE/CHANGE PASS** item.

OVR	CAPS
PASSWORD DEFINING. Password: █	n=0525 p=12 s  12 int

The request to type in a user password is displayed. Enter from 1 up to 8 characters and confirm, and then type in the password again in order to certify. The characters input are not displayed explicitly. Only asterisks (\*\*\*\*\*) are shown on the display.

If the password has already been defined, the **CREATE/CHANGE PASS** item will be followed by as many asterisks as the number of characters within the password is.

### Switching the Password Function On

The password function is enabled to secure *protected commands* against any unauthorised use. The commands are not available until the password function is enabled. The password needs to be defined first. After the password function has been enabled, any access to the menu branches and commands specified above will be preceded by a request to type the password.

In the main MENU select the **TEXT SERVICE** item and then the **ACTIVATE PASSWORD** item. The password function is on from that moment on.

### Changing the User Password

The user password can be changed at any time. In the main MENU select the **TEXT SERVICE** item and then the **CREATE/CHANGE PASS** item.

OVR	CAPS
PASSWORD CHANGING. Password: █****	n=0525 p=12 s  12 int

The request to type in a user password is displayed. Enter from 1 up to 8 characters and confirm, and then type in the password again in order to certify. The characters input are not displayed explicitly. Only asterisks (\*\*\*\*\*) are shown on the display.



**NOTE:** Note that the old password can only be modified (cancelled) when it has been defined to protect the **TEXT SERVICE** branch. Therefore no unauthorised person can modify (cancel) the password.

### Deleting the user password

The user password used to secure *the protected commands* can be deleted.

In the main MENU select the **TEXT SERVICE** item and then the **CREATE/CHANGE PASS** item.



```

                                OVR   CAPS
PASSWORD CHANGING.
Password: ■■■*
                                n=0525
                                p=12
                                S
                                12 int
    
```

The user password is displayed but not explicitly (only asterisks are seen on the display). Delete all characters with the **DEL** key. The system will confirm the action with the **PASSWORD DELETED** message and all security features are then removed.

**NOTE:** If the password has been forgotten, you can contact the Manufacturer (distributor) to cancel the password without entering the **TEXT SERVICE** branch - see section **4.4.5.6 Releasing Protections**.



#### 4.4.1.10. Using Special Registers

Special registers are a specific type of **ASCII** subfile that are updated after each overprint has been made. The register settings can be changed with such events as changing date, changing time, detecting an object by a photodetector, receiving a signal from an external device such as scales.

The **Spec.reg.** parameter indicates whether a given subfile is to be a text file or a special register. You can find it in the parameter menu of the word processor by pressing the **PAR** key.



Type	: Text
Char. set	: Latin 25x15
Typeface	: Normal
Distance	: 2
Rotation	: None
Spec.reg.	: None

The **Spec.reg.** parameter defines the following special registers:

None,	Up counter,	Down count.,	Time,	Date,
Univ.count.,	Univ. date,	Date+offs.,	Date+offs.2,	Spec. chan.

**UWAGA:** W jednym tekście złożonym możliwe jest użycie maksymalnie 6 rejestrów specjalnych.



They are described in the following section.

#### Object Counters

The following counters are used to print a consecutive number on every object automatically:

- **an incremental counter,**
- **a decremental counter.**

The counters are timed by a photodetector. An increment (varying from 1÷9, in ascending or descending order) for both counters is set with the **Counter delta** parameter, which is available in the **PRINTING PARAMETERS** command within the submenu **PRINTING**.

When you edit a subfile that is to be used as an object counter, insert into the subfile a number that consists of so many digits that the entire user-requested range is covered. The number is the initial counter setting. The number can be preceded and followed by any characters.

**EXAMPLE:**

If number 056 has been put into the subfile, then:

- for the incremental counter – after 999 has been reached, the counter is cleared and the counting goes up from zero (056, 057, 058, ... , 999, 000, 001, 002, etc.),
- for the decremental counter – after 000 has been reached, the counter is set to 999 and the counting goes down to zero (056, 055, 054, ... , 000, 999, 998, 997, etc.).



**NOTE:**

- The **object counter** register is also used to print bar codes. Then the bar codes are printed instead of consecutive numbers and the code corresponds to the consecutive number that is counted by the special register. See section **4.4.1.2 Opening and Editing a New File**, paragraph **Subfile type: BAR CODE**.
- The **incremental counter** special register can also count in the hexadecimal format. On selecting the **Spec.reg.=Up counter** parameter from the subfile parameter menu, press the **[PAR]** key and then change the setting of the **Counter type** parameter from **DEC** (the default setting standing for counting in decimal form) to **HEX**.

### **Date and Time**

The **Time** register is used to print current time in the 24-hour system on objects automatically.

The **Date** register is used to print current date in the leap year system on objects automatically.

The structure of date and time registers is similar. If you edit a subfile that is to be a time (date) register, follow the rules below:

- the time (date) register is built of up to 8 meaningful characters (6 digits to be updated and 2 separators),
- when the register is updated, data are input starting from a non-space character until 8 defining characters are inserted or until another space or the end-of-subfile are encountered,
- every third character is treated as a separator; the separator can be any character,
- hours (day), minutes (month), seconds (year) are two-digit numbers and the separator is any non-space<sup>3</sup> character,
- the register can contain less than 8 characters; then the characters are cut off on the right.

**EXAMPLE:**

**Time** is coded in the following way:

**Hours Separator Minutes Separator Seconds** e.g. **00:00:00** or **13/44/56**.

**Hours Separator Minutes** e.g. **00:00** or **13/44**, if seconds are not to be printed.

**Hours** e.g. **00** or **13**, if minutes or seconds are not to be printed.

**Date** is coded in the following way:

**Day Separator Month Separator Year** e.g. **00.00.00** or **17/05/03**.

**Day Separator Month** e.g. **00.00** or **17/05**, if year is not to be printed.

**Day** e.g. **00** or **17**, if month and year are not to be printed.

For more date and time options see the **universal date** register below.

<sup>3</sup>Space – a blank distance between characters; it is inserted with the **[SPACE]** key on the terminal.

## Universal Counter

The universal counter is a special counter to count objects that move before the print head. The counter is timed by a standard photodetector. The universal counter consists of two elements:

- **main counter**,
- **auxiliary counter**.

The **main counter** is always printed, while the **auxiliary counter** either can or cannot be printed.

**The main counter setting changes only when the auxiliary counter has been overflowed!**

Therefore, when you edit a subfile that is to be a universal counter of objects, the subfile should contain the following:

- ➔ If the main and auxiliary counters are printed - two numbers (groups of digits) with so many digits as may be needed to cover the user-defined range. The groups must be separated with a separator that is different from a digit or space. The first group is for the main counter, the second for the auxiliary counter.
- ➔ If the main counter is printed and auxiliary counter is not printed – one number (group of digits) with so many digits as may be needed to cover the user-defined range. The group of digits is for the main counter. The auxiliary counter setting is defined by the **Cnt.value2** parameter - see below.

The operation of two counters depends on the universal counter parameters. To access the parameters start the word processor and follow the procedure below:

- Position the cursor on the subfile that is a special register and press the **[PAR]** key on the terminal,
- Set the parameter **Spec.reg.=Univ.count.**,
- Press the **[PAR]** key on the terminal again. The following universal counter parameters are displayed:

Description	Settings	
• <b>Print beg.</b> - see below,	<b>CONTINUE, BEG.VALUE, MIN/MAX,</b>	
• <b>Mode</b> - see below,	<b>Standard, Special</b>	
• <b>Beg.value1</b> - the initial setting <sup>4*)</sup> ,	0 ÷ 4 294 967 295	} applies to the first element of the universal counter ( <b>main counter</b> )
• <b>Min.value1</b> - the minimum setting <sup>*</sup> ,	0 ÷ 4 294 967 295	
• <b>Max.value1</b> - the maximum setting,	0 ÷ 4 294 967 295	
• <b>Cnt.delta1</b> - an increment,	0 ÷ 255	
• <b>Beg.value2</b> - the initial setting,	0 ÷ 65 535	} applies to the second element of the universal counter ( <b>auxiliary counter</b> )
• <b>Min.value2</b> - the minimum setting,	0 ÷ 65 535	
• <b>Max.value2</b> - the maximum setting,	0 ÷ 65 535	
• <b>Cnt.delta2</b> - an increment,	0 ÷ 255	
• <b>Cnt.value2</b> - the current setting of the counter; it is vital for the auxiliary non-printable counter,	0 ÷ 65 535	

<sup>4\*)</sup> The initial value of either counter can be preset only when the universal counter mode is set to **Standard**. If the mode is set to **Special**, the initial values need to be changed by editing the contents of a subtext within the universal counter.

Description	Settings
<ul style="list-style-type: none"> <li>• <b>0 suppress</b> - Indication whether to hide leading zeros. If the setting is <b>YES</b>, the leading zeros are replaced with spaces in both parts, and both parts are moved to the separator.</li> </ul>	<b>YES, NO</b>
<ul style="list-style-type: none"> <li>• <b>Spc.Md.max</b> - the number of photodetector activations for which unchanged settings of the main counter and auxiliary counter (a sub-counter of the auxiliary counter for identical prints) are to be printed,</li> <li>• <b>Spc.Md.cnt</b> - a continuation value for the <b>Spc.Md.max</b> parameter to be used after the printing has been resumed,</li> <li>• <b>Pal.countr</b> - the number of packages on each pallet – it defines „a jump” by which the value of the main counter should be modified so that packages are numbered with consecutive numbers on the pallets.</li> </ul>	0 ÷ 65 535  0 ÷ 65 535  0 ÷ 65 535

available only for  
**Mode=Special**

Two modes of the universal counter are available and are set with the **Mode** parameter.

1) Universal counter with the parameter **Mode=Standard**.

The first value of the universal counter (i.e. after the **START PRINT** command) that is printed after the printing has been resumed depends on the **Print beg.** parameter. The parameter settings have the following meaning:

- **CONTINUE** – a consecutive value of the universal counter (as defined by other settings). The counting is resumed. A command sequence **STOP PRINTING, START PRINT** does not disturb the consecutive numbering,
- **BEG.VALUE** – both parts of the counter are set with two counter parameters **Beg.value1, Beg.value2**, respectively. The other counters count between the min. and max. settings. With this feature, the printing can be resumed at the point where it has been interrupted, for example, in order to add labels to some missing objects.
- **MIN/MAX** – both parts of the counter are set with two counter parameters **Min.value1, Min.value2**.



**NOTE:**

- The (main, auxiliary) counter setting is increased when its minimum value is smaller than the maximum one. Otherwise it is decreased.
- The (main, auxiliary) counter is overflowed when you switch between its maximum and minimum settings.
- Each time you change the special register type to universal counter, all counter parameters are reset to their initial values, that is  
**Print beg.=CONTINUE, Mode=Standard**  
**Beg.value1=1, Min.value1=1,**  
**Max.value1=4 294 967 295, Cnt.delta1=1,**  
**Beg.value2=1, Min.value2=1,**  
**Max.value2=1, Cnt.delta2=1, Cnt.value2=1,**  
**0 suppress=NO.**
- The overflow of the main or auxiliary counters can additionally be indicated by a change at the output of one of the printer's external ports, and this can optionally be used to control external devices.

In this mode the **Spc.Md.max**, **Spc.Md.cnt** and **Pal.countr** parameters are not available and their values cannot be set.

**EXAMPLE 1:**

**Creating a standard pallet counter.**

**Assumptions:** Packages moving on a factory conveyor are stored on a pallet in single layers, with 4\*5=20 packages in each layer. Packages are placed on the pallet in **A** and **B** order and directions, as shown in the illustration. The pallets are put one onto the other in 4 layers (**C**) on every shelving in the store. The packages need to be labelled in such a way that the pallet number and consecutive package number are printed on each pallet. When the printing is interrupted and then resumed, the consecutive number is printed. After 4 pallets (80 packages) have been labelled, the counter should be reset (i.e. set to its minimum setting) and the counting resumed.

The text file to be printed contains a special register, that is a **universal counter** and the text **000/000** typed via the keypad. Set the counter parameters to the following settings:

<b>Print beg.=CONTINUE,</b>	<b>Mode=Standard,</b>	<b>Beg.value1=1,</b>
<b>Min.value1=1,</b>	<b>Max.value1=4,</b>	<b>Cnt.delta1=1,</b>
<b>Beg.value2=1,</b>	<b>Min.value2=1,</b>	<b>Max.value2=20,</b>
<b>Cnt.delta2=1,</b>	<b>Cnt.value2=1,</b>	<b>0 suppress=NO</b>

The following numbers are printed with the above settings:

001/001, 001/002, ... , 001/020, 002/001, 002/002, ... , 002/020, 003/001, ..... , 004/019, 004/020, 001/001, etc.

**NOTE:** If the numbering of packages has been disturbed for some reason during the printing, the printing can be stopped, the **Print beg.** parameter can be reset to **BEG.VALUE**, both counters can be reset to their initial settings (**Beg.value1** and **Beg.value2**) and the printing can be resumed.

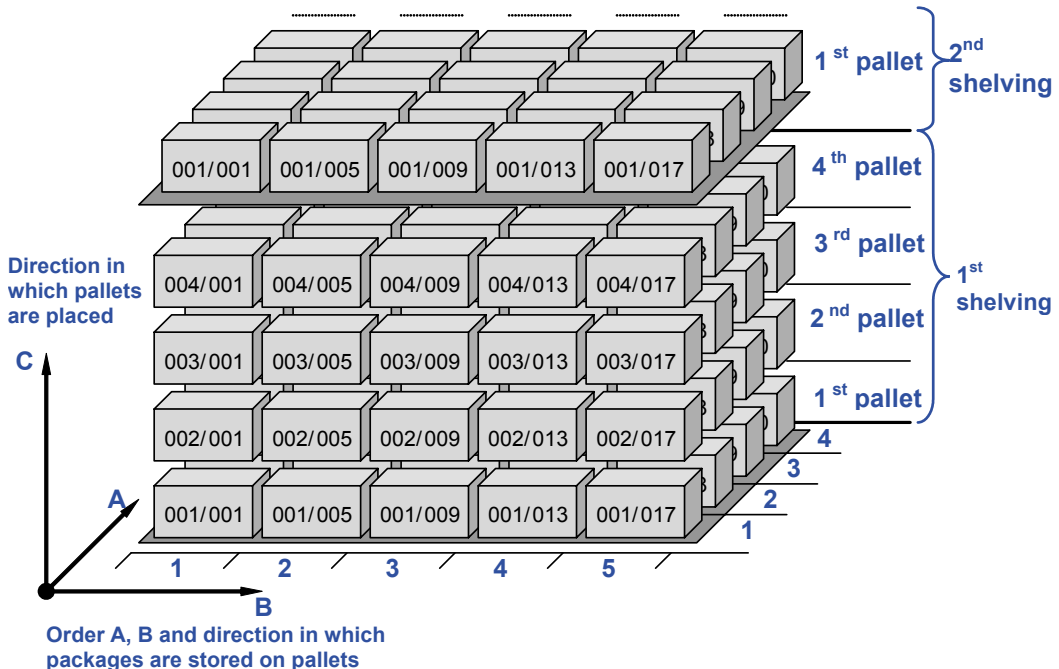

**Fig. 4.4.1.10.1.** The operation of the universal counter used in Example 1

2) Universal counter with the parameter **Mode=Special.**

Additional parameters of the universal counter are available in this mode. They are **Spc.Md.max**, **Spc.Md.cnt** and **Pal.countr** – see the table above. With them the numbering of products can be automated so that the subsequent packing and storing

on pallets or shelves in a hierarchical way is facilitated. In this mode the other parameters are similar to those used in the **Standard** mode except for the **Beg.value1** and **Beg.value2** parameters which are not available and therefore initial values of both counters of the universal counter cannot be set. In the **Special** mode initial values need to be changed by editing the contents (groups of digits separated by a separator) of a subtext of the universal counter.

**EXAMPLE 2:**

**Creating a special counter allowing for peculiarity of product packing in a company.**

**Assumptions:** Small unit packages (products) moving sequentially on a factory conveyor are packed in fours into type I packages, then the type I packages are put in groups of 64 into boxes (type II packages). The type II packages are stored on pallets in one layer, with  $4 \times 5 = 20$  packages in the layer. The packages are arranged on the pallet in **A, B** order and in the direction as shown in the illustration below. The pallets are put one onto the other in 3 layers (**C**) on every shelving in the store. The unit packages need to be labelled in such a way that the type I and type II packages are clearly identified for each product. Therefore the type II package number (the main counter) and type I package number (the auxiliary counter) are printed on each unit package. All products in a type I packaging have the same label (the auxiliary counter). When the printing is interrupted and then resumed, the consecutive number is printed. After products on 3 pallets ( $4 \times 64 \times 60 = 15360$  packages) have been labelled, the counters need to be reset (i.e. set to their minimum settings) and the counting resumed – see the illustration.

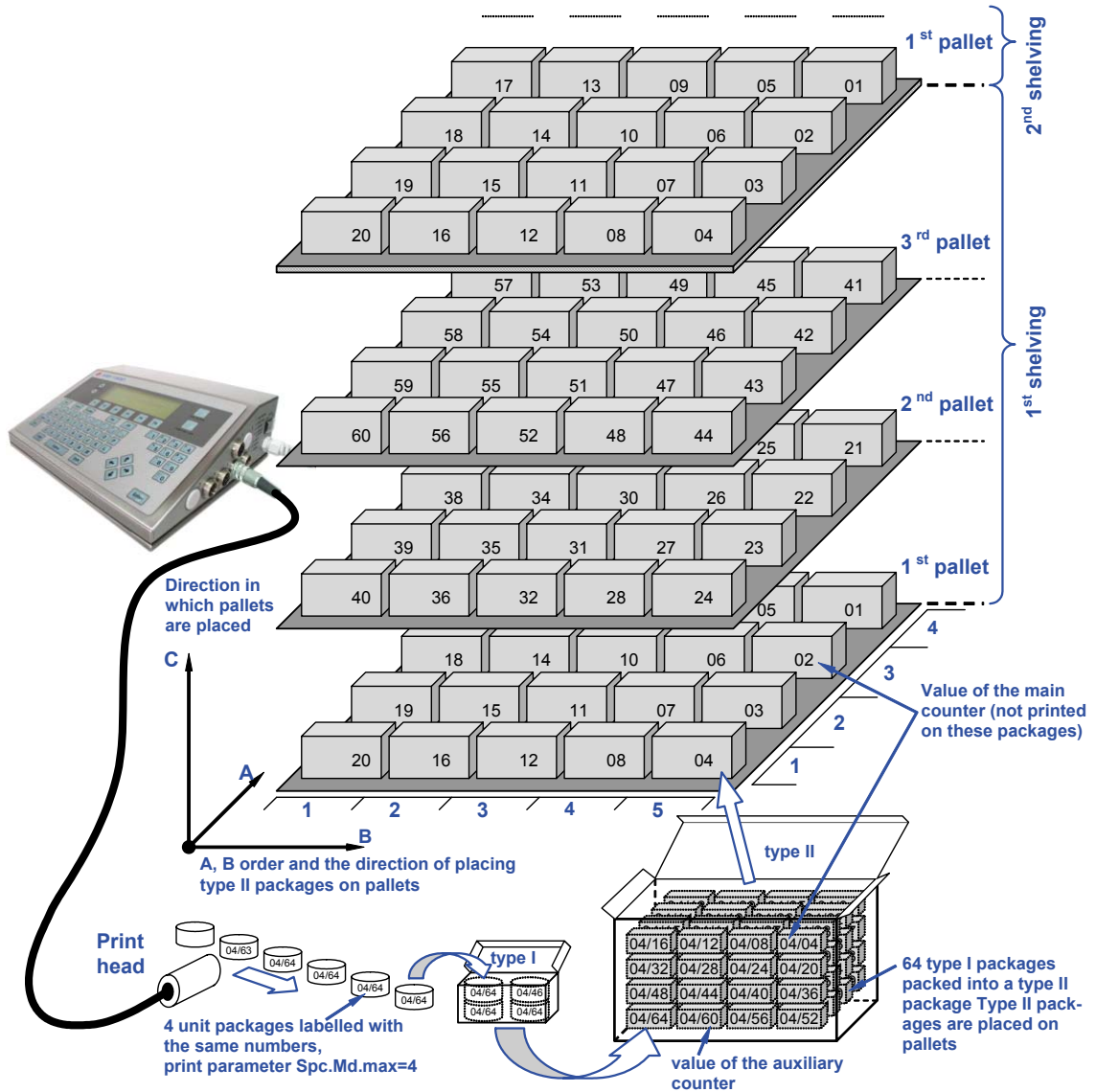

Fig. 4.4.1.10.2. The operation of the universal counter used in Example 2

A subtext needs to be embedded into the text to be printed on packages. It needs to be a **universal counter**-type special register. Its contents of **20/64** should be typed via keyboard. The counter parameters should be set as follows:

<b>Print beg.=CONTINUE,</b>	<b>Mode=Special,</b>	<b>Min.value1=1,</b>
<b>Max.value1=60,</b>	<b>Cnt.delta1=1,</b>	<b>Min.value2=64,</b>
<b>Max.value2=1,</b>	<b>Cnt.delta2=1,</b>	<b>Cnt.value2=1,</b>
<b>0 suppress=NO,</b>	<b>Spc.Md.max=4,</b>	<b>Spc.Md.cnt=1,</b>
<b>Pal.countr=20</b>		

When the above settings are made, the following labels are printed on each of the packages moving on a factory conveyor in front of the print head:

20/64, 20/64, 20/64, 20/64, 20/63, ..., 20/02, 20/01, 20/01, 20/01, 20/01, 19/64, ..., 01/02, 01/01, 01/01, 01/01, 01/01, 40/64, 40/64, 40/64, 40/64, 40/63, ..., 21/02, 21/01, 21/01, 21/01, 21/01, 60/64, 60/64, 60/64, 60/64, 60/63, ..., 41/02, 41/01, 41/01, 41/01, 41/01, **20/64**, etc.

and the counting is resumed↑

**NOTE:** If the numbering of packages has been disturbed for some reason during the printing, the printing can be stopped, groups of digits within the counter subtext



can be re-edited, a continuation value can be set with the **Spc.Md.cnt** parameter and the printing can be resumed.

### **Universal Date and Time**

You can use a special register (**Univ. date**) in order to print current date and time (in various formats) on objects automatically.

Below, there is a list of characters that can be used to encode date and time. Elements of the **universal date** register can be preceded, separated and followed by any characters different from the specified below.

- D** tens of days in the current date,
- A** units of days in the current date,
- M** tens of months in the current date,
- O** units of months in the current date,
- Y** tens of years in the current date,
- E** units of years in the current date,
- B** tens of hours of the current time,
- C** units of hours of the current time,
- I** tens of minutes of the current time,
- J** units of minutes of the current time,
- T** tens of seconds of the current time (option),
- U** units of seconds of the current time (option).

**NOTE:** During printing, the above mentioned date and time components (D, A, M, O, Y, E, B, C, I, J, T, U) are replaced with digits (0-9), as standard. It is also possible that an additional way of coding is used and the above mentioned date and time components are replaced with any characters available from the terminal keypad rather than with digits. The assignment is made in the submenu **TEXT SERVICE** ⇒ **UNIV.DATE REG. CONFIGURATION** ⇒ **DIGIT CODING**. The same characters can be assigned to different digits. For example, the date of **24/10/2004**, coded as **DA/MO/20YE**, can appear on a print as **x\$/HZ/20Z\$**, if the following assignments have been made: **0 => Z**, **1 => H**, **2 => x**, **4 => \$**.

- W** tens of week-of-the-year number,
- K** tens of week-of-the-year number,
- a** number of week of the year coded with one character. The assignment is made in the submenus **TEXT SERVICE** ⇒ **UNIV.DATE REG. CONFIGURATION** ⇒ **WEEK CODING (1 CHAR)**.
- y** tens of year of the current date by week-of-the-year number (e.g. if week 53 ends on 5<sup>th</sup> January next year, then 5<sup>th</sup> January falls within the previous year's week),
- e** units of year of the current date by week-of-the-year number,
- m** number of month printed with the following encoded letters: **A B C D E F G H L M N P** (corresponding to numbers from 1 to 12, respectively). The assignment can be changed in the submenus **TEXT SERVICE** ⇒ **UNIV.DATE REG. CONFIGURATION** ⇒ **MONTH CODING (1 CHAR)**.
- P** hundreds of day-of-the-year number,
- Q** tens of day-of-the-year number,
- S** units of day-of-the-year number,
- N** number of day of the week (1- Monday, 2-Tuesday, ... , 7-Sunday),
- F** the first letter of the month,
- G** the second letter of the month,
- H** the third letter of the month,
- b** the number (between 0 and 23) of the hour of day of current time coded with a single character. The assignment of any character available via the terminal keypad to each hour of day is made in the submenu **TEXT SERVICE** ⇒ **UNIV.DATE REG. CONFIGURATION** ⇒ **HOURLY CODING (1 CHAR)**. The same characters can be assigned to different hours.



**Z** working shift identifier. Working shifts identified by numbers **1**, **2** or **3** cover the following time periods as standard:

- 1<sup>st</sup>** shift - from 6:00 to 14:00, **2<sup>nd</sup>** shift - from 14:00 to 22:00,
- 3<sup>rd</sup>** shift - from 22:00 to 6:00, on every day of the week.

A shift identifier can be set for each of up to 8 working shifts (within a 24-hour day), so can shift start and finish times for each shift separately on working days (from Monday to Friday) and on the other days (Saturday and Sunday).

In order to change the settings select the item **SHIFT DEFINITION** from the submenu **TEXT SERVICE** ⇒ **UNIV.DATE REG. CONFIGURATION**. A list of additional parameters of the special register *Universal date and time* is displayed for the coding element **Z** of this register, that is for the shift identifier. This is where the following parameters can be modified.

- Any alphanumerical character available on the terminal keypad can be used as identifier.
- The shift start time needs to be specified as the sequence of **hh:mm** (hours:minutes). The shift times need to be specified in such a way that the following condition is met: the next shift needs to start later than the previous one.
- If a character **X** is specified instead of a shift start time, it means that a given and subsequent shifts do not exist, and the identifier is printed in accordance with the previous shifts' parameter settings.

**NOTE:**

- The shift identifiers and start times are global parameters in the printer. This means that every subfile in the text-file library that is a *Universal Date and time* special register and contains the **Z** element of the register uses the same set of shift identifiers and start times.
- The standard version does not support any update of tens or units of seconds (parts **T** and **U** in the **Univ. date** register). When such function is supported, the printer processor is engaged frequently (every second) to update the text file and the maximum print rate might be reduced.



**EXAMPLE:**

When you define a subfile as a **Univ. date** special register and input the following characters (□ stands for a space character):

a) **DA.MO.20YE=DA□FGH□20YE□□□BC:IJ□□□PQS□□□WK□□□N□□□Z**

b) **EYOM/DZAF<PGQH>SC\*\*\*BIJQ###SPW---NK**

then the following labels are printed on 12.01.2004 at 12:35:50:

a) **12.01.2004=12 JAN 2004 12:35 012 02 6 1**

b) **4010/112J<0A1N>22\*\*\*1350###120---62**

### **Expiry Date Registers**

In order to print automatically a future date that is shifted by a certain number of days from the current date, you can use two special registers **Date+offs.** and **Date+offs.2** (expiry date registers).

The offset (a number of days added to the current date in order to calculate the expiry date) is defined by two parameters, **Offset** (for the **Date+offs.** register) and **Offset2** (for the **Date+offs.2** register) in the **PRINTING PARAMETERS** command within the **PRINTING** menu.

The structure of the **Date+offs.** and **Date+offs.2** registers is similar to that of the **Univ. date** register (see special register - *Universal date and time*) and this means that **individual parts of the date need to be coded with the characters (!)** that are used in the **Univ. date** register.

**EXAMPLE:**

The **Date+offs.** and **Date+offs.2** registers can be coded in the following way:

- |                                           |                                                                                                   |
|-------------------------------------------|---------------------------------------------------------------------------------------------------|
| <b>Day Separator Month Separator Year</b> | for example <b>DA.MO.YE</b> (a separator can be any character that is not used to code the date), |
| <b>Day Separator Month</b>                | for example <b>DA.MO</b> , if year is not to be printed,                                          |
| <b>Year Separator Month Separator Day</b> | for example <b>YE.MO.DA</b> .                                                                     |

Any combination of coding characters defined for the **Univ. date** register can be used.

**Data from Special Channel**

The special channel is used to transfer data from peripherals (such as a computer, automatic scales, bar code reader) to the printer. The data can be printed automatically via a special register called **special channel**.

While editing a subfile that is the special channel register, insert to the subfile as many characters (they can be any characters) as the peripheral may transfer. The purpose is to define the register length. During the printing the characters are replaced with special channel data in the following way:

- If the number of characters transmitted from the special channel is smaller than the register length, additional spaces added on the right side,
- If the number of characters transmitted from the special channel is greater than the register length, the excessive number of characters is cut off on the right side.

**EXAMPLE:**

The printer is connected with automatic scales and the subfile has been defined as the **Spec. chan.** register. The subfile contains, for example:

**XXXXXXXXXX or 1234567890**

When the following data are transferred from the scales: **"netto: 75g",**  
**"netto: 1250g"**

the subfile is printed as follows:

- |                   |                                                                    |
|-------------------|--------------------------------------------------------------------|
| <b>netto: 75g</b> | the entire text is printed.                                        |
| <b>netto: 125</b> | the text is shortened as this register is only 10 characters long. |

**4.4.2. Using Print-parameter Blocks**

Operations on parameter blocks are available in the **PARAMETERS SERVICE** menu.















**NOTE:**

If the MENU branch **TEXT SERVICE** is protected with a user password (!), you are asked to type the password before the **PARAMETERS SERVICE** submenu is displayed. For details on how to use the user password see section **4.4.1.9 Using the Password**.

Parameter blocks are stored in a library in the printer memory. Each block goes with an up to eight-character name. The name can contain alphabetical small and block letters, digits and some other characters except spaces, dots and characters such as: \ / : \* ? " < > |, for example, **12345678**, **AB#%CD&**, **WEIGHT-5**, **JUICES**, **DATETIME**, **Q1**, **star@ice**, **W\$%S**, etc. Every parameter block contained in the library can have the **read only** attribute assigned

to it to prevent it from being deleted or modified by an unauthorised person. The **read only** attribute can be assigned to/removed from a single parameter block or all block in the library. For more information refer to paragraph [4.4.2.6 Accessing the Parameter Block Library](#).

Block names are arranged in alphabetical order. The following facilities enable the user to move along the block directory freely:

- the     keys to move the cursor from one block name to the other,
- the leading character (a letter or digit) to move the cursor to the first name that starts with this character,
- the   (**HOME**) or   keys to move the cursor to the first name in the library,
- the   (**END**) or   key to move the cursor to the last name in the library.

**NOTE:**

If the printer memory is overfilled (with a lot of or very long text files or parameter blocks), the parameter-block names may not be arranged in alphabetical order and some facilities may not be effective.



#### 4.4.2.1. Creating and Editing a New Parameter Block

In the main MENU select the **PARAMETERS SERVICE** item and then the **CREATE NEW BLOCK** item, type in a block name consisting of up to eight characters and confirm.

**NOTE:**

- If the block name already exists in the library, the parameters are displayed on the terminal and can be edited.
- **Once the parameter block has been created, it remains in the printer memory even after power supply has been switched off. The block can be deleted.**















After the name has been typed in, a parameter processor is used to input settings. All parameters in the parameter menu have their default settings<sup>5</sup>. Any modifications (for modifications see below) need to be confirmed and then a new parameter block with the user-defined name is formed in the library.

For linking parameter blocks with subfiles see section [4.4.1.8 Linking File Names with Parameter-block Names](#).

### Modifying Parameters

The following keys help you to move along the parameter list or to modify settings:

- the  and  keys move the cursor to parameter fields.
- the   (**HOME**) or   keys position the cursor on the first parameter setting,
- the   (**END**) or   keys position the cursor on the last parameter setting.

Changes to the settings of each of the parameters are made with the  and  keys. Numerical settings can also be input directly from the keypad and confirmed with the  key.

<sup>5</sup>Default setting – initial setting suggested by the Manufacturer.



**NOTE:**

The creation or edition of a parameter block have no impact on current settings - see section [4.4.3.4 Print Parameters](#).

#### 4.4.2.2. Editing Existing Blocks of Parameters

In the main MENU select the **PARAMETERS SERVICE** item and then the **EDIT PARAM. BLOCK** item.

The display shows the parameter block library from which a block name should be selected (see also section [4.4.2 Using Print-parameter Blocks](#)).

The parameter block processor starts running and you can modify the parameter settings. After the settings have been modified and the modifications confirmed, the parameter block is stored in the library.

For linking parameter blocks with subfiles see section [4.4.1.8 Linking File Names with Parameter-block Names](#).



**NOTE:**

The edition or modification of a parameter block have no impact on current settings. For details see section [4.4.3.4 Print Parameters](#).

#### 4.4.2.3. Copying and Editing Blocks of Parameter

You can create a new block of parameters by copying an existing block and saving it with a different name. In the main MENU select the **PARAMETERS SERVICE** item and then the **COPY & EDIT BLOCK** item.

The display shows the parameter block library from which you should select the name of the block to be copied (see also section [4.4.2 Using Print-parameter Blocks](#)).

Type a name (up to eight characters) and confirm the name by pressing the **ENTER** key.

If the newly typed block name already exists in the library, the **BLOCK NAME EXISTS** message is displayed:

The parameter processor starts running and the settings can be edited. The process goes in the same way as described in section [4.4.2.2 Editing Existing Blocks of Parameters](#).

#### 4.4.2.4. Deleting a Block of Parameters

In the main MENU select the **PARAMETERS SERVICE** item and then the **DELETE PARAM. BLOCK** item.

The display shows the parameter block library from which you should select the name of a block to be deleted, and then confirm the selection (see also section [4.4.2 Using Print-parameter Blocks](#)).



**NOTE:**

Once deleted the block cannot be restored.

#### 4.4.2.5. Deleting the Parameter-block Library

If you delete the block library, it means that all parameter blocks contained in the printer's memory are deleted. In the main MENU select the **PARAMETERS SERVICE** item and then the **CLEAR PARAM.LIBRARY** item.

When confirmed, the parameter blocks are deleted **irretrievably**.







#### 4.4.2.6. Accessing the Parameter Block Library

Viewing the parameter library means viewing all parameter blocks stored in the printer's memory. In the main MENU select the **PARAMETERS SERVICE** item and then the **READ LIBRARY** item.

PARAMETERS			CAPS
!TEXT-5.	12345678	ABCD...	n=0525
DATE....	+EXDA....	+ICE.....	p=12
LOGO....	+NUMBER-1	NUMBER-4	s
+SHIFTNO.	TIME....	WEIGHT..	12 int

The names of parameter blocks are displayed in the terminal's operating window in alphabetical order. In this window you can view parameter blocks, assign the **read only** attribute to the blocks to protect the blocks from being deleted or modified by unauthorised persons and also remove the attribute. The blocks with the **read only** attribute assigned to them are marked with a "+" sign that precedes the block names. The attribute markers ("+" or "space") are also displayed with the **EDIT PARAM. BLOCK** and **COPY & EDIT BLOCK** commands but they cannot be modified with these commands.

The following functions are available while the parameter block library is viewed:

Terminal key	Function
	Moving the cursor along the names of parameter blocks.
An alphabetical or numerical key	To display the parameter block names starting from the first name that begins with a given character.
	To place the cursor on the first name in the library.
	To place the cursor on the last name in the library.
	To assign/remove the <b>read only</b> attribute to/from a selected parameter block. The operation is available only when the service password is enabled. If the password level is too low, you will be asked for a password when you make an attempt to change the attribute.
	To assign the <b>read only</b> attribute to every block in the library. The option is available only when the service password is enabled. If the password level is too low, you will be asked for a password when you make an attempt to change the attribute.
	To remove the <b>read only</b> attribute from every block in the library. The option is available only when the service password is enabled. If the password level is too low, you will be asked for a password when you make an attempt to change the attribute.

**NOTE:**  
 If no parameter blocks are defined in the library, the command is ignored.

### 4.4.3. Printing

#### 4.4.3.1. Stopping the Printing

The printing can be terminated in two parallel and independent ways:

- With the **STOP PRINTING** command selected on the terminal.
- With the **PRINT ON/OFF** key on the operation-panel function pad (when the key is pressed, the **STOP PRINTING** command is executed). The key can be used no matter where the cursor is positioned within the control menu (for example, you can stop the printing while editing a subfile).

To stop the printing follow the procedure below.

In the main MENU select the **PRINTING** item and then the **STOP PRINTING** item.

or

Press the **PRINT ON/OFF** key on the operation panel.

If the command is selected while the printer is in the *print* mode, the current print job finishes and no other label is printed. The printer switches to the *stop* mode.

If the printing is to be interrupted immediately (the current print job is not to be completed), use the **QUICK STOP** command

#### 4.4.3.2. Starting the Printing

The printing can be initiated in two parallel and independent ways:

- With the **START PRINT** command selected on the terminal.
- With the **PRINT ON/OFF** key on the operation-panel function pad. When the key is pressed, the latest subfile is printed. The key can be used no matter where the cursor is positioned within the control menu (for example, you can start the printing while editing a subfile).

The printing is started in the following way. In the main MENU select the **PRINTING** item and then the **START PRINT** item.

OVR		CAPS
Text name: ABCD		n=0525
Block name: STANDARD		p=12
		s
<b>ALT</b> names menu		12 int

You are prompted to specify a text file name. Type in an up to 8-character name and confirm, or alternatively, you can press the **ALT** key.

		CAPS
Select text name:		n=0525
12345678 <b>ABCD</b> ...	DATE....	p=12
EX_DATE. GROSS-WT	ICEcream	s
LOGO.... NET-WT..	NUMBER-1	
NUMBER-2 NUMBER-3	QWERTY*1	12 int

The display shows the text file library from which you should select the name of a text file to be printed (selection facilities are described in section [4.4.1.1 Introduction to Text Files](#)).

If the printer is ready to print (the *stop* mode), then the printing starts as soon as the subfile name has been selected. The printer switches to the *print* mode.

**NOTE:**

- If the message **CHANNEL ACTIVE** is displayed after the **START PRINT** command has been selected, this means that the printer is in the *print* mode. Stop the printing (with the **STOP PRINTING** or **QUICK STOP** commands) and repeat the **START PRINT** command.
- If the message **TEXT NAME DOES NOT EXIST** is displayed after the **START PRINT** command has been selected, this means that the subfile name does not exist in the library.



#### 4.4.3.3. Quick Stopping the Printing

If the printing is stopped in the regular mode, the current print job is always finished to the end. However, a need may arise to stop printing immediately regardless of the state of the print job.

The printing is interrupted in the following way. In the main MENU select the **PRINTING** item and then the **QUICK STOP** item.

If the command is selected while the printer is in the *print* mode, the printing is interrupted and any further printing is suppressed. The printer switches to the *stop* mode.

If the printing is to be stopped but the current print job is to be finished, use the **STOP PRINTING** command.

#### 4.4.3.4. Print Parameters

With **EBS** printers you can make overprints on objects with a wide range of shapes and sizes. The objects can be moved in their normal position or “upside down”, automatically or manually, in front of the print head at various speeds and in any direction (left or right). Character height, width, thickness, number of repetitions and many other print parameters can be modified to fit your requirements.

The following parameters can be modified:

**Vertical Direction,**  
**Initial Distance,**  
**Number of Repetitions,**  
**Distance Between Overprints,**  
**Horizontal Direction,**  
**Overprint Height,**  
**Date Offset 1,**  
**Date Offset 2,**  
**Counter Increment,**  
**Row Repetition,**

**Ink drop Intensity,**  
**Timing Mode,**  
**Character Resolution,**  
**Conveyor travel speed** (for an internal generator) or **Number of Pulses Generated by External Encoder** (for an external SHAFT-ENCODER),  
**Number of purging rows during the automatic nozzle-purge procedure,**  
**Purge period during the automatic nozzle-purge**

Overprints are made with the adoption of **current parameters** that might differ from those stored in the parameter-block library (see section **4.4.2 Using Print-parameter Blocks**). The current settings decide what is printed on real objects.



The current parameters (called parameters further on) can be modified in the following way:

- Before the **START PRINT** command has been selected (the *stop* mode) you can modify all parameters that are available for the **PRINTING PARAMETERS** command in the **PRINTING** menu. The file to be printed may not be linked with any parameter block.
- In the *print* mode (after the **START PRINT** command has been selected) you can modify the major part of parameters (but not all of them), which are available for the **PRINTING PARAMETERS** command.



- ➔ When a file together with a parameter block linked to it are selected in the **START PRINT** command, the settings from the block are valid. The parameters can be modified during the printing.

### Modifying Print Parameters

Default settings for print parameters are as follows:

<b>Vert. direct.</b>	<b>UP</b>	
<b>Space</b>	<b>2.0 mm</b>	
<b>Text rpt.</b>	<b>1</b>	
<b>Rpt.dist.</b>	<b>30.0 mm</b>	
<b>Direction</b>	<b>LEFT</b>	
<b>Height</b>	the maximum for a given head type	
<b>Offset</b>	<b>1</b>	
<b>Offset2</b>	<b>1</b>	
<b>Counter delta</b>	<b>1</b>	
<b>Row repetit.</b>	<b>1</b>	
<b>Intensity</b>	<b>70</b>	
<b>Generator</b>	<b>GEN</b>	
<b>Resol.dot/dcm</b>	<b>60</b>	
<b>Cnv spd m/min or</b>	<b>10</b>	Only when <b>Generator=GEN</b> or
<b>Enc const p/m</b>	<b>10000</b>	Only when <b>Generator=SHAFT</b>
<b>No of Clean Strokes</b>	<b>0</b>	
<b>Clean. period (sec)</b>	<b>300</b>	

The following keys help you to move along the parameter list or modify settings:

- ➔ the **↓** and **↑** keys move the cursor to parameter fields.
- ➔ the **SHIFT** **←** (**HOME**) or **SHIFT** **↑** keys position the cursor on the first parameter setting.
- ➔ the **SHIFT** **→** (**END**) or **SHIFT** **↓** keys position the cursor on the last parameter setting.

The setting of each of the parameters can be modified with the **→** and **←** keys. The setting of a numerical parameter can also be input directly from the keypad and confirmed with the **ENTER** key.

Below there is a detailed description of print parameters, range of settings, default settings and an indication whether the parameter can be modified during the printing.

**A detailed description of the print parameters (according to pattern shown in the table below) is give further in this document.**

1	Parameter name displayed in the parameter menu	A description of the print parameter
2	Range of settings	
3	Default setting	
4	Can it be modified during printing?	

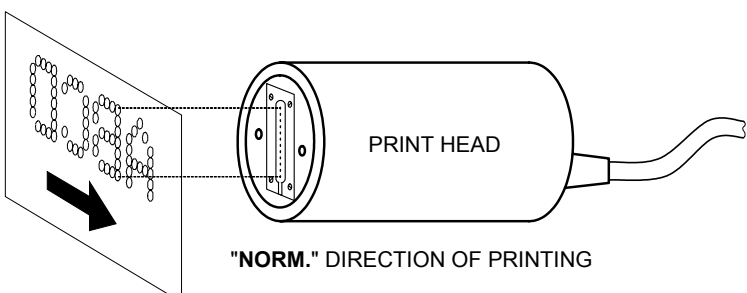

**Vertical Direction**

1	<b>Vert. direct.</b>	<p>The parameter defines two modes of printing in the vertical direction: normal or "upside down". It is useful when the object labelled is reversed.</p>  <p style="text-align: center;"><b>Fig. 4.4.3.4.1.</b></p>
2	<b>UP,DOWN</b>	
3	<b>UP</b>	
4	<b>YES</b>	

**Initial Distance**

1	<b>Space</b>	<p>The parameter defines the distance given in millimetres, from the point where the photo detector has been activated to the point where printing of a text file should start. During printing the distance is measured off properly provided that the settings of the <b>Cnv spd m/min</b> parameter (for <b>Generator=GEN</b>) and the <b>Enc const p/m</b> parameter (for <b>Generator=SHAFT</b>) correspond to real measurements taken at the print place. It enables a user to adjust the print position in relation to the edge of the object to be labelled.</p>
2	0,0 ; 0,1 ; ... ; 6553,5 mm	
3	2,0 mm	
4	<b>YES</b>	

**Number of Repetitions**

1	<b>Text rpt.</b>	<p>The parameter defines how many times the overprint is to be made after the photo detector has been activated, from the point where the overprint begins. It is used to print a subfile on an object many times. For continuous objects such as cables, hoses or tubes you can set continual printing. Distance between consecutive overprints is defined with the <b>Rpt.dist.</b> parameter - see below.</p>
2	1, 2, 3, ... , 65534, <b>CONTIN.</b>	
3	1	
4	<b>YES</b>	

### Distance Between Overprints

1	<b>Rpt.dist.</b>	The parameter defines the distance given in millimetres <u>between the beginnings of texts</u> when they are printed repeatedly ( <b>Text rpt.&gt;1</b> ). During printing the distance is measured off properly provided that the settings of the <b>Cnv spd m/min</b> parameter (for <b>Generator=GEN</b> ) and the <b>Enc const p/m</b> parameter (for <b>Generator=SHAFT</b> ) correspond to real measurements taken at the print place.
2	0,0 ;0,1 ; ... , 6553,5 mm	
3	30,0 mm	
4	YES	



**NOTE:**

If the distance set with the **Rpt.dist.** parameter is smaller than the length (number of rows) of overprints, the overprints are separated with four blank rows.

### Horizontal Direction

1	<b>Direction</b>	The parameter defines in which direction, left or right, objects move in front of the print head. With this setting, the printer makes overprints in the horizontal direction to ensure the overprints are clearly visible. The direction is defined when looking from the head.
2	<b>LEFT, RIGHT</b>	
3	<b>LEFT</b>	
4	YES	

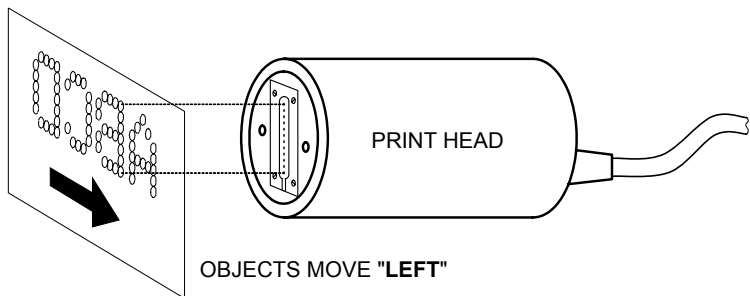

**Fig. 4.4.3.4.2.**

### Overprint Height

The overprint height can only be changed by turning the head around the axis that is perpendicular to the object. When the head is turned, the distance (in vertical direction) between drops reduces and therefore the total overprint height is smaller.

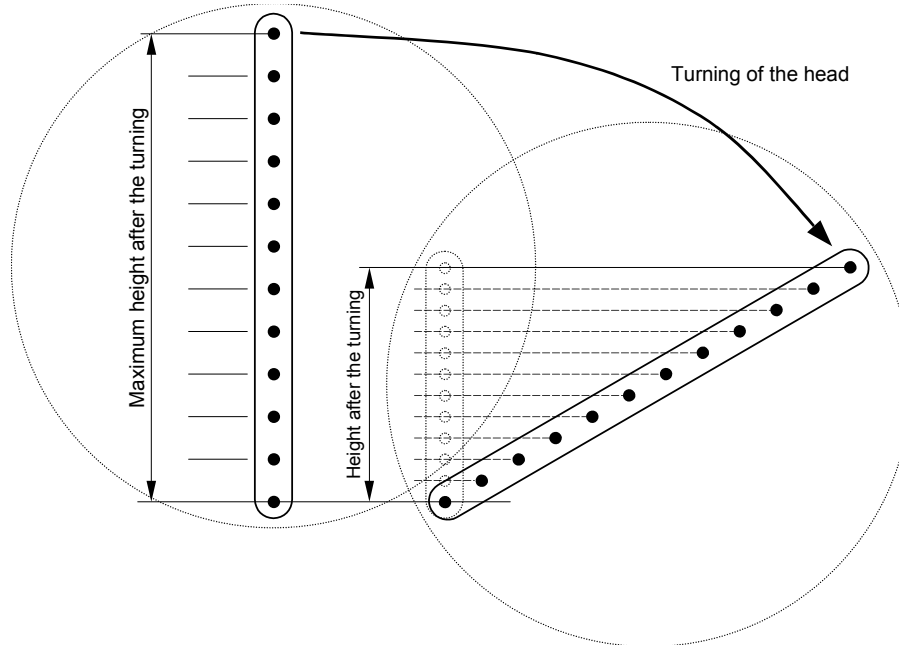

1	<b>Height</b>	The parameter defines the print height.
2	From the maximum height (the head is not turned) to the minimum one (to ensure the overprints are still visible) for a 12-nozzle electromagnetic head the overprints can be <b>20, 14, 9, 6, 5</b> mm high.	
3	Maximum for unturned head	
4	NO	

Moments when ink drops are jetted are calculated and adjusted in order to ensure that rows are printed vertically and the proportion of character width to height is maintained for the entire overprint. Therefore the range of turning angles is restricted. Every turning angle corresponds to a different overprint height. The height is defined by the **Height** parameter and it is measured in millimetres. The height relates to the entire overprint, no matter how the subfile has been created or what its contents are.



**NOTE:**

- If the height setting differs from the maximum setting, there is a close relation between the following three items: turning angle, **Resol.dot/dcm** and **Cnv spd m/min**. If any of them change, vertical rows slant left or right. To ensure that the vertical rows are printed vertically, i.e. at no angle, follow the procedure below:
  - at first adjust the turning angle to ensure that the real overprint height (that is the distance between the lowest and the highest dot) is the same as the height set with the **Height** parameter.
  - then modify the **Resol.dot/dcm** and **Cnv spd m/min** parameters to „straighten out” vertical rows.
- The overprint height cannot be adjusted by changing the distance between the head and objects.
- The target height of a text printed with a turned print head depends on the following:
  - the diameter of print-head nozzles,
  - the type of ink,
  - the pressure of air in the print head,
  - the absorption of the surface labelled.
  - the setting of the print parameter **Intensity**.

**Date Offset**

1	<b>Offset, Offset2</b>	The parameter defines a number of days to be added to the current date in order to calculate the so-called expiry date. There are two offset parameters: <b>Offset</b> and <b>Offset2</b> . The expiry date register is a special register <b>Date+offs.</b> or <b>Date+offs.2</b> , where the above parameters are used - see also section <b>4.4.1.10 Using Special Registers</b> .
2	0, 1, 2, 3, ... , 9999	
3	1	
4	YES	

**Counter Increment**

1	<b>Counter delta</b>	The parameter is a number added to an incremental counter or subtracted from a decremental counter. The incremental or decremental counters are special registers where the <b>Counter delta</b> parameter is used- see also section <b>4.4.1.10 Using Special Registers</b> .
2	1, 2, 3, ... , 9	
3	1	
4	YES	

**Row Repetition**

1	<b>Row repetit.</b>	The parameter defines how many times each vertical row should be printed to get the overprint. It applies to the entire text file, no matter how the file has been created, what its contents are and how many times individual subfiles are to be repeated. The possibility to increase the row repetition is useful, especially when prints are made on porous surfaces or the surfaces that become soaked easily, in order to increase print intensity.
2	1, 2, 3, ... , 10	
3	1	
4	NO	

### *Ink drop Intensity*

1	<b>Intensity</b>	You can change the intensity of ink drops. This parameter affects the size (volume) of ink drops that are jetted out of the print head. The effect of the increased intensity are a larger dot diameter and higher saturation of the ink colour on the overprint.
2	50, 51, 52, ... , 255	
3	70	
4	YES	

**UWAGA:**

- Any increase in the intensity increases ink consumption.
- The setting range for the **Intensity** parameter is limited but not only to what is specified in the table above. The real setting is controlled by the control program and may be restricted by settings made for other print parameters. The system is automatically protected against an excessive print speed setting. Therefore it may happen that some settings are not accepted.



### *Timing Mode*

1	<b>Generator</b>	The print rate is controlled by an internal generator or a shaft-encoder. The internal generator (or shaft-encoder) is responsible for proper timing, that is for deciding when vertical rows should be printed. The <b>Generator</b> parameter is used to select the timing source - see also section <b>4.6 Adjusting the Print Rate</b> .
2	<b>GEN, SHAFT</b>	
3	<b>GEN</b>	
4	NO	

### *Character Resolution*

1	<b>Resol.dot/dcm</b>	The parameter decides how visible characters and symbols are after they have been printed. It defines image resolution, which is a number of <b>drops per decimetre</b> . A visual effect of a change in the <b>Resol.dot/dcm</b> parameter is a change in the width of characters and the length of the entire overprint - see also section <b>4.6 Adjusting the Print Rate</b> .
2	1, 2, 3, ... , 400	
3	60	
4	YES	

**NOTE:**

- The setting range for the **Resol.dot/dcm** parameter is limited but not only to what is specified in the table above. The real setting is controlled by the control program and may be restricted by settings in other print parameters. The system is automatically protected against an excessive print speed setting. Therefore it may happen that some settings are not accepted.
- When the print head is slanted at a certain angle, i.e. the setting of the **Height** parameter is smaller than the maximum height, the **Resol.dot/dcm** parameter is additionally restricted to the settings that ensure vertical direction of rows on overprints. A prerequisite is that the **Cnv spd m/min** parameter should be set to the real travel speed of the conveyor.



### Conveyor travel speed

1	<b>Cnv spd m/min</b>	<p>Overprints are printed clearly visible when the row print frequency matches the conveyor travel speed. To ensure the matching, set the <b>Cnv spd m/min</b> parameter with an appropriate value of the conveyor travel speed. The parameter is measured in a number of meters travelled by the conveyor during a minute.</p> <p>The travel speed can also be measured with a service command <b>CONVEYER MEASUREMENTS</b> - see also section <a href="#">4.4.4.1 Defining Some Print Parameters with the Conveyor Travel Speed</a> and <a href="#">4.6 Adjusting the Print Rate</a>.</p>
2	0,1 ; 0,2 ; ... ; 2500	
3	10,0	
4	YES	



**NOTE:**

The setting range for the **Cnv spd m/min** parameter is limited but not only to what is specified in the table above. The real setting is controlled by the control program and may be restricted by settings in other print parameters. The system is automatically protected against an excessive print speed setting. Therefore it may happen that some settings are not accepted.

### Number of Pulses Generated by External Encoder

1	<b>Enc const p/m</b>	<p>The shaft-encoder, a travel speed indicator is mechanically coupled with the conveyor and provides timing pulses that ensure proper printing. The number of timing pulses depends on the encoder type and on the transmission gear between the encoder and conveyor. The <b>Enc const p/m</b> parameter is a number of encoder pulses per unit distance (1 metre) that is covered by moving objects. It can also be measured with a service command <b>CONVEYER MEASUREMENTS</b> - see also section <a href="#">4.4.4.1 Defining Some Print Parameters with the Conveyor Travel Speed</a> and <a href="#">4.6 Adjusting the Print Rate</a>.</p>
2	50, 51, 52, ... , 300000	
3	10000	
4	YES	

### Number of purging rows during the automatic nozzle-purge procedure

1	<b>No of Clean Strokes</b>	<p>If no print has been made for a longer time, it may happen that dots of various sizes appear in the first rows to be printed when printing is resumed. The <b>No of Clean Strokes</b> print parameter defines the number of full rows to be printed to purge the nozzles. Such rows are inserted in place of space before a text (the space is defined by the <b>Space</b> parameter). The time which elapsed from the moment the last print was made and after which the automating nozzle-purge procedure is followed is defined by the <b>Clean. period (sec)</b> parameter. If the <b>No of Clean Strokes</b> parameter is set to 0, the automatic nozzle-purge procedure is disabled.</p>
2	0, 1; 2; ... ; 15	
3	0	
4	YES	

**Purge period during the automatic nozzle-purge procedure**

1	<b>Clean. period (sec)</b>	The <b>Clean. period (sec)</b> parameter defines the time (in seconds) which has elapsed since the last print was made and after which the automatic nozzle-purge procedure should start. If the time defined with the <b>Clean. period (sec)</b> parameter expires before a successive print is made, the purging rows are printed, with the number of such rows being defined with the <b>No of Clean Strokes</b> parameter. If a successive text is due for printing during the purging procedure, the procedure is interrupted and the text is printed.
2	20, 21; 22; ... ; 4095	
3	300	
4	YES	

**NOTE:**

- The automatic nozzle-purge function does not change the space between texts to be printed because the purging rows are inserted only in place of the space.
- No ending or resumption of printing has any impact on the counting of time defined with the **Clean. period (sec)** parameter.
- At least two empty rows are always placed before the first character of a text.



**4.4.3.5. Saving Current Parameters in a Block**

Some print parameters can be modified during the printing to customise them to your needs. The modified parameters can be introduced to the block library with their names and saved in the printer memory.

In the main MENU select the **PRINTING** item and then the **SAVE CURRENT PARAM.** item.

OVR	CAPS
Block name: PAR-1	n=0525 p=12 p 12pix 12 int
<b>ALT</b> names menu	

You are prompted to specify the name of a block where the parameters are to be saved. Type in an up to 8-character block name and confirm, or alternatively, you can press the **ALT** key.

CAPS	
Select block name: 87654321 DATE_PAR EXDA-PAR <b>PAR-1...</b> PAR-2... STANDARD TIME_PAR	n=0525 p=12 p 12pix 12 int

The display shows the parameter block library from which you should select the name of a parameter block and save the parameters under this name (for a description of block selection facilities see section **4.4.1.1 Introduction to Text Files**).

On selecting an existing name you have to decide whether you wish to overwrite the existing block or not.



**NOTE:**

- If the menu branch **TEXT SERVICE** is protected with a user password, the **SAVE CURRENT PARAM.** command is followed by a request to type the password. For details on using the user password see section [4.4.1.9 Using the Password](#).
- When the name of a nonexistent block has been typed, a new block is created.
- When the name of an existent block has been typed, the block is replaced with new parameters (after this has been confirmed).

#### 4.4.3.6. Controlling Object Counters

The printer can count the objects it labels. Each time the photo detector is activated, the object counter is incremented by 1. The counter can be reset or set to any initial setting at any time.

**The printer is supplied with two separate object counters.**

**A change counter**, which can be viewed at any time, but modifications can be controlled with a user password. Any modification (in particular resetting to zero) does not affect the global counter.

**A global counter**, which is protected with a user password against unauthorised access or modifications. Any modification (in particular resetting to zero) does not affect the change counter.

#### Accessing object counters

In order to access an object counter follow the procedure below. In the main MENU select the **PRINTING** item and then the **SHIFT COUNTER** or the **GLOBAL COUNTER** item.

CAPS	
S. COUNT : 1514	n=0525 p=12 p 12pix 12 int

or

CAPS	
G. COUNT : 25486340	n=0525 p=12 p 12pix 12 int

The current setting of the object counter is displayed. Each time the photodetector is activated, the object counter setting is increased by 1 and this can be viewed on the display. Press any key to get back to the main menu.

#### Modifying Object Counters

In order to modify an object counter follow the procedure below. In the main MENU select the **PRINTING** item and then the **SET SHIFT COUNTER** or the **SET GLOBAL COUNTER** item.



OVR	CAPS
S . COUNT : 0	n=0525 p=12 P 12pix 12 int

or

OVR	CAPS
G . COUNT : 0	n=0525 p=12 P 12pix 12 int

The current setting of the object counter is displayed. Each time the photodetector is activated during the printing, the object counter setting is increased by 1 and this can be viewed on the display.

Input the required setting and confirm or press any key (different from numerical keys), if you wish to leave the counter unchanged.

In particular, if you set the counter to 0 (zero), it is cleared.

**NOTE:**

If the menu branch **TEXT SERVICE** is protected with a user password, then **a request to type the password appears before the global counter setting is displayed or before the global or change counters are made available to modifications**. For details on using the user password see section [4.4.1.9 Using the Password](#).



#### 4.4.3.7. Printing with the use of a code switch

In order to change the text file during the printing, select the following sequence as standard: the command **STOP PRINTING**, the command **START PRINT** and the name of a text file to be printed.

If the text file to be printed is modified frequently, EBS series printers offer a text-file selection facility and with it the text file can be changed in a simple and quick way. The facility uses a so-called code switch which is available in two versions:

- (1). *Standard* – a code switch emulated by the printer terminal and initiated by pressing the **F5** terminal key. After a four-digit text-file name has been typed in via the keypad, the **ENTER** key needs to be pressed at the moment when a new text is expected to be printed.
- (2). *Option* – a code switch as an external EBS-manufactured device to be connected to an additional female connector on the printer's housing. It is equipped with a simple keypad and a display. It offers a number of additional functions except for ordinary functions of a typical code switch.

More information about printing with the use of a code switch is given in a separate document.

#### 4.4.3.8. Viewing Files on the Terminal Display

You can view the text file being printed. In the main MENU select the **PRINTING** item and then the **DISPLAY PRINTED TEXT** item.

The text file being printed is shown on the terminal display, for example the **ABCD** file as shown below.

ABCD	CAPS
<b>***INK-JET***</b> <b>EBS-1500</b>	n=0525 p=12 p 12pix 12 int



**NOTE:**

- The **DISPLAY PRINTED TEXT** command is available only when the printer is in the *print* mode.
- If special registers are used in the text file to be printed, their settings can be reviewed (after a relevant command has been selected). The only exception is the special register *universal date* where only coding characters are shown instead of date in one of the formats available.

#### 4.4.4. Servicing the Head

##### 4.4.4.1. Defining Some Print Parameters with the Conveyor Travel Speed

In the main MENU select the **SERVICE** item and then the **CONVEYER MEASUREMENTS** item.

Place two objects on the conveyor at a distance of one metre (**1m**) one from the other and make them move before the photodetector after the **CONVEYER MEASUREMENTS** command has been selected. The terminal display shows you real settings for the following parameters:

- Conveyor travel speed shows a number of metres covered by the object within a minute (**m/min**). The value can be used directly to make a setting and to determine a setting for the print parameter **Cnv spd m/min**.
- Number of pulses generated by the external encoder (in fact by the encoder + mechanical gears, if any) per unit distance (**pulses/m**). This is the so called encoder constant. The value can be used directly to make a setting and to determine a setting for the print parameter **Enc const p/m**.



**NOTE:**

- In order to determine the encoder constant correctly, the print parameter **Generator** must be set to **SHAFT** and the encoder axis must rotate while the measurement is taken.
- If the **Generator** parameter is set to **GEN**, the encoder constant is 0 (zero).
- The distance between the objects can be smaller or greater than 1 metre. In such a case the reading should be divided by the distance (x 1m.). For example, if the distance is 0.2m, then the real encoder constant is five times greater than that shown on the terminal.

##### 4.4.4.2. Other Commands

The **OTHERS** item can also be selected from the **SERVICE** menu. It gives the service person or a qualified person access to an extended list of service commands (after the service password has been typed in).

## 4.4.5. Auxiliary Commands

### 4.4.5.1. System information

In the main MENU select the **AUX. COMMANDS** item and then the **OPTIONS** item. Information menu is shown on the display. It contains the following data:

- Serial number of the controller (the final part of the number that is stamped on the back wall of the controller housing) and a number that is the maximum height of the overprint (in other words, the number of independent nozzles within the print head),
- Estimate ink level in the ink bottle – the machine records all ink dots made during the printing and having compared them with the total bottle capacity, it specifies a percentage of the ink consumption,
- Version numbers for the main printer control program and terminal program.

### 4.4.5.2. Accessing Alarm Messages

Every error indicated by an alarm is logged in the printer's memory in the form of a report. The report includes data such as the type of error and the date and time of occurrence. It enables the operator to review printer operation by studying untypical events.

When an error or failure and an alarm occur, you can try to interpret the type of error by selecting the **DISPLAY ERRORS** command from the **AUX. COMMANDS** submenu. An error message is displayed on the terminal in response.

A precise description of an error report is given in a separate document (*Accessing Error Report in EBS-1500 & EBS-6000 Series Printers via the READ ERRORS REPORT command*).

### 4.4.5.3. Setting Date and Time

The printer is equipped with a real-time clock, which operates even after the power supply has been switched off. It is possible for the user to set the date and clock time, however, the modification of the date is protected with a special service password.

In the main MENU select the **AUX. COMMANDS** item and then the **TIME AND DATE** item.

Then, the date and time indicated by the clock are displayed in the working window on the terminal where they can be modified. The date can be modified in the **SERVICE** submenu after the special service password has been specified.

	OVR	CAPS
DATE : 24 . 09 . 05		n=0525
TIME : 11 : 03 : 31		p=12
		s
		12 int

In the main MENU select the **SERVICE** item and then the **OTHERS** item. On typing in the service password, select the **SET TIME AND DATE** item. In this place you can confirm or modify the time and date settings that are displayed consecutively.

**NOTE:**

- **Date cannot be set back!**
- If you try to set a past date, the following message is displayed on the terminal: **DATE IS SET BACKWARD !!**. You will find it impossible to start printing with the **START PRINT** command. The command is followed by the error message:



#### 4.4.5.4. Checking the Printer Run Hours

A built-in inner clock is used to run a printer operation timer to check how long the printer has been running since it was swithed on for the first time.

In the main MENU select the **AUX. COMMANDS** item and then the **ACTIVITY TIME** item.

CAPS	
BUSY TIME:1264:25	n=0525
WORK TIME LEFT:UNLIMITED	p=12
	s
	12 int

The number of hours and minutes are displayed in the operating window on the terminal.

#### 4.4.5.5. Choosing a Language

You can specify the language in which the control MENU and all messages are displayed on the terminal.

In the main MENU select the **AUX. COMMANDS** item and then the **LANGUAGE** item.

CAPS	
Select language:	n=0525
<b>ENGLISH</b>	p=12
POLSKI	s
FRANCAIS	
DEUTSCH	12 int

A list of languages available is displayed in the operating window on the terminal. You can communicate with the printer in any of them.

After a language has been selected, the control menu is immediately displayed in the selected language.

**NOTE:**

If you have selected a language that you do not understand, you can set the printer back to the **ENGLISH** language by pressing the following key sequence on the terminal: **[ESC][ESC][ESC][ESC][ESC] 5 [ENTER] 7 [ENTER]**, then selecting the language and confirming the selection.

#### 4.4.5.6. Releasing Protections

The following protections have been used in the printer:

1) Protected access to the following commands (**protected commands**):

- ➔ all commands within the menu branch **TEXT SERVICE**,
- ➔ all commands within the menu branch **PARAMETERS SERVICE**,
- ➔ commands within the menu branch **PRINTING**. such as:
  - **SAVE CURRENT PARAM.**,
  - **SET SHIFT COUNTER**,
  - **GLOBAL COUNTER**,
  - **SET GLOBAL COUNTER**.

The menu branches mentioned above can be protected with a user password. If the user forgets the password, the protection can be released by **cancelling the user password**.

- 2) An operation time limit assigned to a user by the manufacturer (or distributor under a separate agreement). When the limit expires, the printer stops working automatically. Then the printer stops responding to user commands. Only the release protection command can be executed. The assigned time limit can be prolonged by 50, 100 or 200 hours, or possibly the limit can be cancelled and the unit released from any operational constraints.

In the main MENU select the **AUX. COMMANDS** item and then the **UNLOCK PROTECTION** item.

In order to get the protection released, contact the Manufacturer (distributor) by telephone and describe what kind of protection is to be released.

After the **UNLOCK PROTECTION** command has been selected, a nine-digit code is displayed in the operating window on the terminal. The code is used to calculate the password.

OVR	CAPS
4C9E907AX: █	n=0525 p=12 s  12 int

Reveal the code to the Manufacturer representative but do not exit the command or press any key (especially the printer switch-off key). You will be given a coded password to release the protection. Type the coded password and press the **ENTER** key. If you make a mistake or type in a wrong code, the device enables you to input the code ten times before you will have to contact the manufacturer or your distributor. After ten unsuccessful attempts the message **Switch the PRINTER off and on** is displayed and the protection remains enabled.

OVR	CAPS
4C9E907AX: 5D83A46C█	n=0525 p=12 s  12 int

If the proper code is typed in, the printer confirms this fact by displaying the **\*\*OK\*\*** message and the user-indicated security feature is disabled.

**NOTE:**  
If the user had to exit the command while waiting for a return code and has now repeated the command **UNLOCK PROTECTION**, then the code obtained will be invalid and will not help release the protection. Only a return code entered properly soon after the original code, while the **UNLOCK PROTECTION** command is active, will allow the protection to be released.



## 4.4.6. Replacing ink bottle

### General information

Every bottle of ink is equipped with a transponder (an electronic circuit where bottle identification data are stored and can be accessed with no need for wire contact or additional power supply). The information is scanned from the transponder with a built-in Ink Monitoring System (the abbreviation **IMS** shall be used hereinafter) that uses an aerial situated in the Ink System. **Fig. 4.4.6.1** shows the position of the aerial.

**NOTE:**

**Fig. 4.4.6.1** shows the position of the ink monitoring system if the printing system works with a compressor system. The position of the transponder seat (and the aerial of the Ink Monitoring System) for the ink system with an ink pump is described in the document entitled *Ink System with an Ink Pump*.

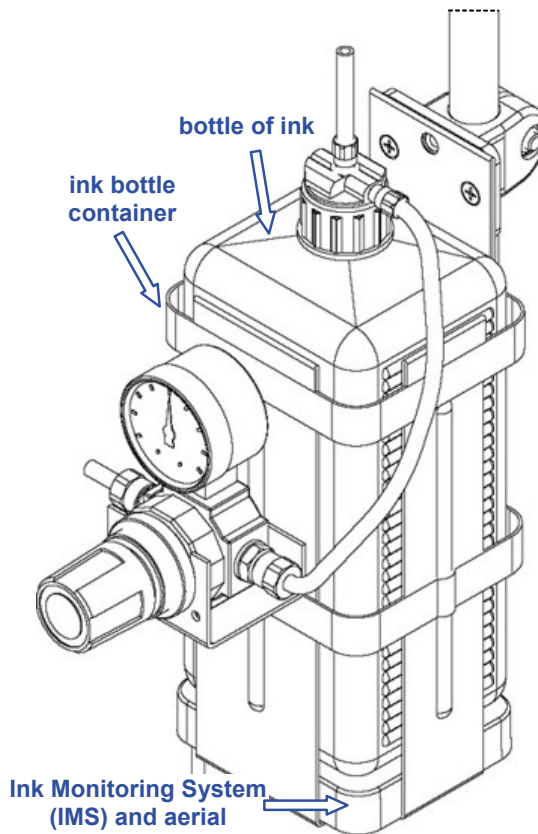

**Fig. 4.4.6.1.**

The Ink Monitoring System ensures that:

- 1) The bottle is identified explicitly.
- 2) The printer system is checked continuously for appropriate ink. **IMS** prevents the application of the ink that is different from the one that was used in the printer's ink system originally. Type of the consumable and its service life are checked.
- 3) Ink distribution and monitoring are improved as the information is coded and validated electronically in every transponder.



Each bottle can be only used in one printer for which it was accepted by **IMS**. Approved bottles cannot be moved to other printers and other bottles cannot be replenished with the fluid from the approved bottle. The approved bottle should remain in the printer until the fluid is consumed.

If **IMS** messages concerning the ink bottle are displayed in the main window on the terminal display, they are preceded by the indication "**INK:**", whereas if they are displayed in the printer status window, they are preceded by the first letter of the indication, that is "**I:**". For example:

MENU	CAPS
INK: NO BOTTLE Press ENTER...	I:NO B OTTLE

## ***Replacing the bottle of ink***

**In order to avoid unnecessary troubles while replacing empty ink bottles, follow the procedure given below - see also the description given in section [2.3.5 Installing a new Bottle of Ink \(or Replacing an Empty One\)](#).**

1. Assess the amount of ink in the bottle visually. If the ink level in the bottle goes down below 10% of the bottle volume, prepare a new bottle. The bottle is completely empty when broken labels are produced. Should a user perform substandard operations, then the following message may be displayed:  
**INK:  
EMPTY BOTTLE**  
Some systems are equipped with low ink level detectors. If the low ink level is detected, the following message is displayed on the terminal: **INK LACK**. In such a case discontinue the printing with the command **STOP PRINTING** and reduce the ink pressure to zero!
2. Remove the empty bottle from the container - the following message can be displayed on the terminal:  
**INK:  
NO BOTTLE**
3. Place a new sealed bottle (but do not insert a suction pipe to the bottle). One or more messages may be displayed. If this is the proper bottle, that is, a new bottle that has never been used (or approved) before, the following message should appear at first:  
**BOTTLE VERIFYING:  
WAIT 10 SECONDS PLEASE**
4. If a message **BOTTLE ACCEPTED** is displayed within 10 seconds, it means that the bottle is right for a given printer. In such a case remove the bottle and unseal it. Then put a suction pipe tipped with a filter into the bottle, screw the bottle into the cap and place it in the container (a **NO BOTTLE** message can be displayed in the meantime). Set the rated pressure.
5. If no bottle error occurs, the message **NO BOTTLE** should be replaced with the normal status indication in the printer status window. Resume the printing with the command **START PRINT**.

With this the replacement procedure finishes.





**NOTE:**

- Do not refill an empty bottle with ink, as **IMS** will consider the bottle unsuitable. Every new bottle is assigned a time limit and after the expiration of the time limit the bottle is considered unsuitable even if it is not empty – see section **4.4.6.2 Checking the calculated ink consumption level**. Under normal conditions the bottle is always emptied during the normal operation of the printer before the time limit expires.
- If no new bottle has been approved within 30 minutes after the empty bottle alarm has been indicated, the printing ceases. Replace the bottle with a new one and clear the alarm with the clear alarm button.
- Do not remove the bottle while it is being validated by the system (about 10 seconds).
- Every bottle can be used only in the printer where it has been approved by **IMS**. The approved bottles must not be moved to other printers or used to refill other bottles. The bottle approved should remain in the printer container until ink is consumed.
- The above procedure for replacing an ink bottle should be followed when a compressor system is used. A description of how to replace an ink bottle in the system equipped with an electromagnetic head and the ink system with an ink pump is contained in the document entitled *Ink System with an Ink Pump*.

**4.4.6.1. Checking the validity date**

Ink is fit for use over a limited time and the expiration of the time limit is indicated on the terminal:

MENU	CAPS
INK: BOTTLE TOO OLD Press ENTER...	I: BOTT LE TOO OLD

From that moment till the moment the ink bottle is replaced with a new one, no printing is possible in order to avoid any damage to the ink system.

The service life is coded in the transponder and can be displayed and viewed on the terminal at any time in the following way.

In the main MENU select the **BOTTLE INFORMATION** item and then the **INK EXPIRE DATE** item. The message indicating the expiry date for ink contained in the bottle that is attached to the ink system is then displayed on the terminal.

	CAPS
INK EXPIRE DATE: 20.06.05	n=0525 p=12 P 12pix 12 int



The validity date can be checked provided that the current date has been set in the printer properly. **If the date has been set back, no printing can be made.** Any attempt to start printing results in an error message.



**NOTE:**

- After the date has been set back, all bottles are ignored! The validation of bottles and the printing will not be resumed until the proper date has been set in the printer.
- Do not set the date ahead because any subsequent attempt to set the proper date will be recognised as setting back, and the consequences described above will apply.



#### 4.4.6.2. Checking the calculated ink consumption level

Every new bottle of ink is associated with a limit of ink drops. When the limit is reached, the bottle is recognised empty even if it is not completely empty. Ink drops jetted out of the print head are counted and the ink consumption is estimated. Therefore no ink should be added to the empty bottle, as the Ink Monitoring System will recognise the bottle empty soon anyway. During the normal operation of the printer, the bottle is usually emptied before the limit is reached.

In order to check the calculated level of ink remaining in the system till the limit is exceeded, go to the main MENU, select the **BOTTLE INFORMATION** item and then the **INK LEVEL** item.

After the service password has been typed in, the percentage of ink consumed out of the bottle is displayed in the operating window on the terminal.

If the above-mentioned limit is exceeded, the printer will react as if the bottle of ink has been drained.

The second lines shows the number of text files currently in use which can be printed with the ink remaining in the ink bottle and (after a semicolon) the number of text files which can be printed with the use of 1 litre of ink. These are approximate figures. If the head is not in the *print* state, then --- is displayed in the second line. If division results in an overflow, then vvv is displayed in the second line. In such a case, you need to extend the printed text, for example, 3 times and multiply the results by 3 in order to get the results for the original, unextended text.



#### 4.4.6.3. Accessing information in the Ink Monitoring System

It is sometimes necessary to access information that is subject to testing and validation by **IMS** in the printer. This is especially important when **EBS** printers with different inks or different ink systems need to be serviced.

In the main MENU select the **BOTTLE INFORMATION** item and then the **PRINTER/INK/SOLV. TYPE** item.

The operating window on the terminal displays a table containing all required information according to the type of printer and consumables used, e.g.:

							CAPS	
	Pigm	HdTyp	Capac	Subt			n=0525	
	Base	Colour	Econom				p=12	
Printer:	--	01	00	05	--	--	s	
LastInk:	00	01	00	05	03	--	00	
L.v.bot:	00	01	00	05	03	00	00	12 int

Characters -- mean that a given parameter is undefined. If ink parameters appear to be inconsistent with the corresponding printer parameters, an error may be indicated. Bottle data relate to the last-validated ink bottle. A bottle has been validated only when the following message has been displayed for this bottle:

**BOTTLE VERIFYING:  
 WAIT 10 SECONDS PLEASE**



#### 4.4.6.4. Problems that might arise in the printer operation when a bottle of ink is replaced

##### Flow diagram for the ink monitoring system

The block diagram given below shows the operation of the Ink Monitoring System, errors that may occur and a user's actions to be taken after the errors have occurred.

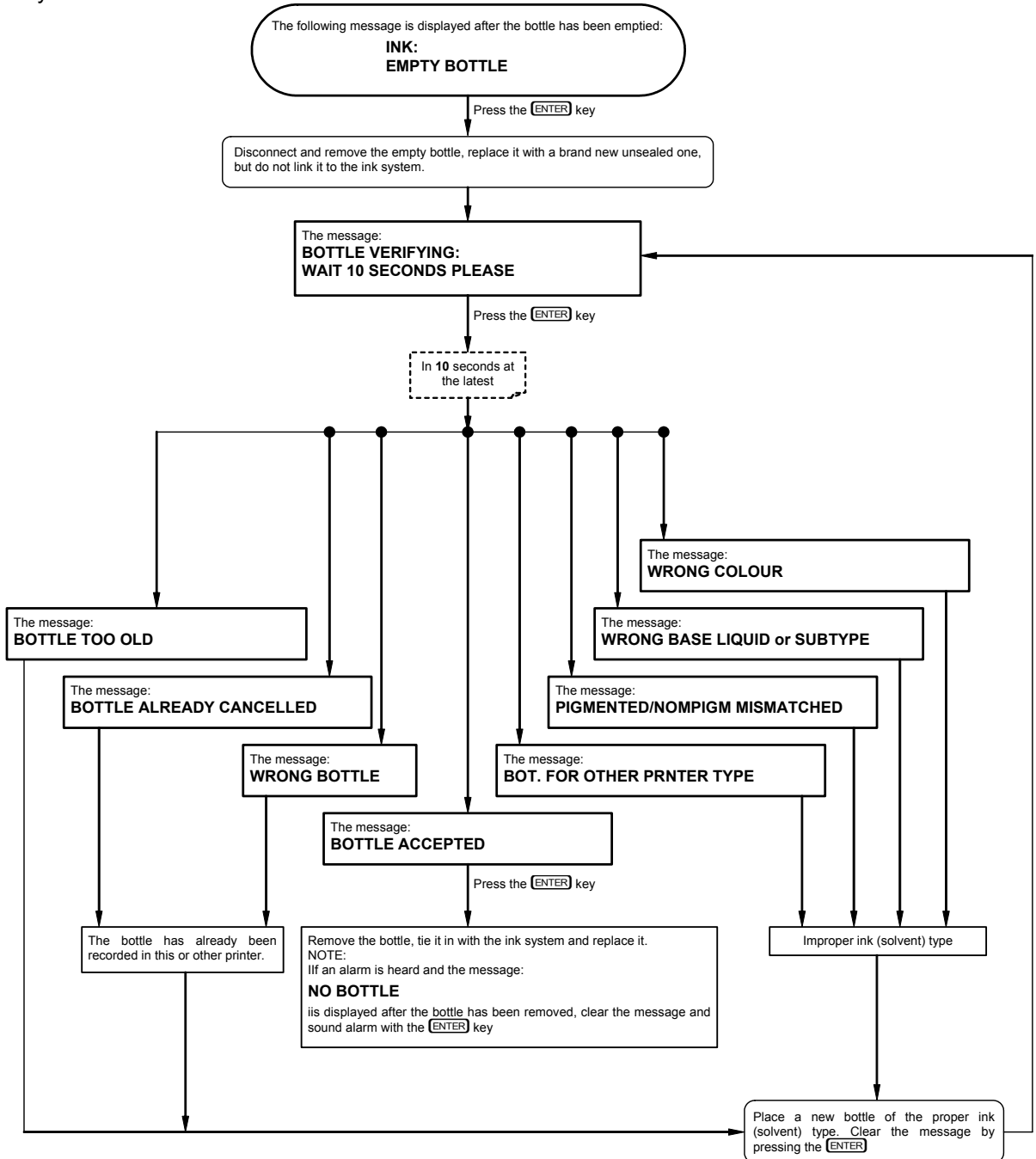

Fig. 4.4.6.4.1.

**UWAGA:**

**Fig. 4.4.6.4.1** relates to the printing system equipped with a compressor system. The position of the transponder seat (and aerial of the Ink Monitoring System) in the case the ink system with an ink pump is used is described in the document entitled *Ink System with an Ink Pump*.

## 4.5. Alarms, Errors and Indications

Alarms are indicated in two ways:

- a). An alarm message is displayed in the operating window on your terminal no matter what operation is being executed at that moment (you might be editing a file). A reason for the alarm is indicated in the message. To clear the alarm press the **ENTER** key on the terminal panel. The sound alarm, however, is not cleared.
- b). A built-in beeper is heard.

**NOTE:**

The printer can be optionally equipped with a device designed for:

- controlling a big light signalling device installed on an outrigger,
- controlling other pieces of equipment (after a fatal error has occurred and further printing has been disabled) via built-in relays, in order to, for example, automatically stop a factory conveyor or the printing.

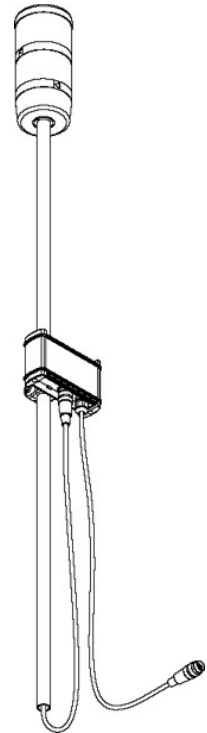

### 1. No ink in the ink bottle

Terminal message: **INK LACK.**

Replenish ink by replacing the empty bottle with a full one - see section **2.3.5 Installing a new Bottle of Ink (or Replacing an Empty One)** and **4.4.6 Replacing ink bottle**. Then clear the alarm by pressing the clear alarm key



### 2. No ink bottle or transponder.

The Ink Monitoring System cannot detect a transponder (the **NO BOTTLE** message); the transponder should be located above it in the bottle basket (under the ink bottle), if a compressor system is used, or on the casing of the pump-based ink system, if such a system is used (a detailed description is given the document entitled *Ink System with an Ink Pump*)

You can use the terminal after the **ENTER** key has been pressed but the no ink-bottle message is still indicated in the status window.

PRINTING	CAPS
1 STOP PRINTING	I:NO B
2 START PRINT	OTTLE
3 QUICK STOP	
4 PRINTING PARAMETERS	
5 SAVE CURRENT PARAM.	

You are not able to start the printing then. The **START PRINT** command is followed by the error message.

Place the right bottle of ink or a transponder (if the ink system with an ink pump is used) above the ink monitoring system. Check also for the proper connection of **IMS** interfaces (by screwing tight the female and male connectors).

- Ink in the bottle is not fit for use any longer (the prescribed time has been exceeded)**

Terminal display:

MENU	CAPS
INK: BOTTLE TOO OLD Press ENTER...	I:BOTT LE TOO OLD

Ink in the bottle is not fit for use any longer as the prescribed time has just expired. If you use unsuitable ink, the head or ink system might get damaged.

If you try to select the **START PRINT** command in this condition, the error message is displayed.

Replace the ink bottle with a new one after you have checked that the prescribed time for the new bottle has not been exceeded - see section [2.3.5 Installing a new Bottle of Ink \(or Replacing an Empty One\)](#) and [4.4.6 Replacing ink bottle](#).

### 4.5.1. Clearing Alarms

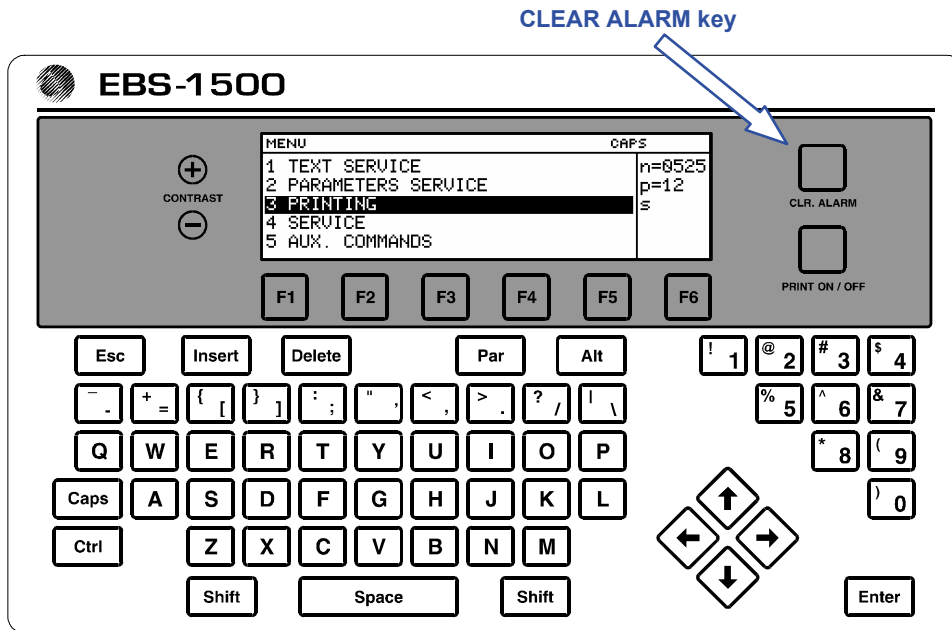

Fig. 4.5.1.1.

To clear the alarm press the **CLR. ALARM** key on the terminal panel.

**NOTE:**

Do not clear any alarm before you have identified what the source of the alarm is.



### 4.6. Adjusting the Print Rate

The print head is motionless during the printing. Overprints are made on objects that move in front of the head. The range of print rates varies according to application. Therefore the printer has been equipped with a feature that enables you to adjust the rate to make clear and legible overprints in every condition. The printing operation is timed with pulses that are generated by two sources:

- a controlled internal generator,
- an external encoder, which converts rotational speed to pulse frequency.

If you increase or decrease the pulse frequency, you change the print rate.

#### 4.6.1. Internal Generator

The internal generator operates regardless of the rate at which objects travel in front of the print head. That is why it is used with **conveyors whose travel rate is specified and stable**.

The pulse frequency generated by the internal generator (and thereby the print rate) depends on two print parameters (the **PRINTING PARAMETERS** command in the **PRINTING** menu):

- The **Cnv spd m/min** (see section [4.4.3.4 Print Parameters](#)) parameter adjusts the print rate (in rows) to the conveyor travel speed (m/min). If the setting of the **Cnv spd m/min** parameter does not change and you reduce the travel speed, the density of characters printed increases.

To set the **Cnv spd m/min** parameter correctly, measure the travel speed with the service command **CONVEYER MEASUREMENTS** - see section [4.4.4.1 Defining Some Print Parameters with the Conveyor Travel Speed](#).

- ➔ The parameter **Resol.dot/dcm**, which defines an image resolution. The resolution is given as a number of dots/decimetre. A visual effect of a change to the parameter is a change in the width of characters (graphic images) and the length of the entire text file.



**NOTE:**

For print parameters **Resol.dot/dcm** and **Cnv spd m/min** extreme setting ranges are specified. Settings are adjusted by the control program on an on-going basis and may be limited with settings that are made for other print parameters. The system is protected automatically against an excessive print rate setting. Therefore some settings may not be accepted.

Below you can see a sample overprint "ABCD" that differs for various settings of the **Resol.dot/dcm** parameter; the travel speed is constant (NOTE: in order to make the overprint legible, it is shown not to scale):

**Resol.dot/dcm: 60**      ABCD

**Resol.dot/dcm: 30**      ABCD

**Resol.dot/dcm: 15**      ABCD

Rough measurements of the timing frequency (print rate) can be taken with the **ROWS SPEED** command in the **PRINTING** menu. The value depends on setting of the print parameters **Generator**, **Resol.dot/dcm** and **Cnv spd m/min** in the **PRINTING** menu.

#### 4.6.2. Shaft-encoder

The shaft-encoder is an electromechanical indicator of rotary speed. The shaft-encoder axle is coupled mechanically with an object that moves, for example, on a conveyor. Pulses are generated at the shaft-encoder output. The pulse frequency is proportional to the rotational speed of the axle. The pulses determine when rows of overprints are to be printed. The pulse frequency depends on the following:

- Conveyor travel speed,
- Transmission ratio of a mechanical gear between the object moving and shaft-encoder axle,
- Encoder type i.e. number of pulses generated during one rotation.

Therefore the external encoders are used to time conveyors whose travel speed varies or is unstable.

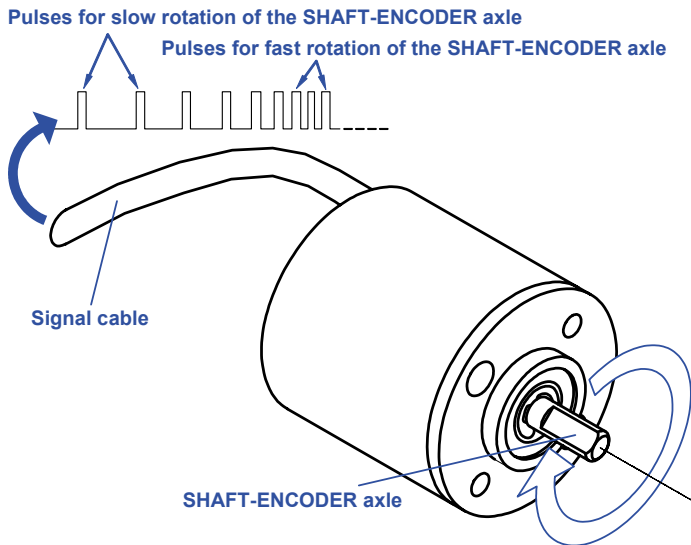

We are not going to describe types of mechanical gears to be applied to couple mechanically encoders with conveyors as there is a variety of solutions available to meet specific user requirements.

Fig. 4.6.2.1. Shaft-encoder

The timing frequency (print rate) is influenced by two print parameters (see the **PRINTING PARAMETERS** command in the **PRINTING** menu):

- The **Enc const p/m** (see section [4.4.3.4 Print Parameters](#)) parameter defines the number of shaft-encoder pulses that are generated while the objects are covering a distance of **1m**. If the shaft-encoder is used for timing purposes and the **Enc const p/m** parameters is set to a constant value, no increase or decrease in the conveyor travel speed has any impact on the width of characters printed.

The **Enc const p/m** parameter can be set with the encoder constant that is measured with the service command **CONVEYER MEASUREMENTS** - see also section [4.4.4.1 Defining Some Print Parameters with the Conveyor Travel Speed](#).

- The parameter **Resol.dot/dcm** (see section [4.4.3.4 Print Parameters](#)), which defines an image resolution. The resolution is expressed as a number of dots/decimetre. A visual effect of a change to the parameter is a change in the width of characters (graphic images) and the length of the entire text file

Below you can see a sample overprint "**ABCD**" that differs for various settings of the **Resol.dot/dcm** parameter; conveyor travel speed is constant (NOTE: in order to make the overprint legible, it is shown not to scale):

**Resol.dot/dcm: 60**



**Resol.dot/dcm: 30**



**Resol.dot/dcm: 15**

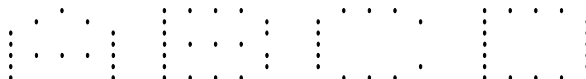

As the printer can not control the frequency of pulses generated by the encoder, the frequency limit might be exceeded and the overprint might be deformed - see section [6.4 When Problems Arise while Operating or Servicing the Printer](#). In order to get correct overprints, select the timing frequency and settings for the print parameters: **Resol.dot/dcm**, **Enc const p/m** and **Intensity** in such a way that the overprints are not strained.





**NOTE:**

- The maximum pulse frequency at the shaft-encoder input shall not exceed **250kHz**.
- If the printer is equipped with electromagnetic heads, there is a print parameter **Intensity**, which affects the maximum pulse frequency. Any increase in the intensity results in a decrease in frequency to the following formula:

$$f = \frac{22000}{\text{Intensity}} \quad [\text{kHz}]$$

where:

**f** - frequency [kHz] of pulses at the shaft-encoder input,  
**Intensity** - setting of the **Intensity** parameter.

### 4.6.3. Defining the Maximum Print Rate for Various Fonts

In order to define the maximum print rate for a font selected (also called a character matrix) follow the procedure below:

1. Open a text file in the **TEXT SERVICE** menu and use the font for which the maximum print rate is to be measured.
2. Use the **PRINTING PARAMETERS** command in the **PRINTING** menu to set print parameters, in particular **Intensity**, **Resol.dot/dcm** as required and also
  - the **Generator** parameter to **GEN**,
  - the **Cnv spd m/min** parameter to a relatively small value (e.g. close to the lowest possible setting),
3. Start printing the text file with the **START PRINT** command in the **PRINTING** menu.
4. Check on the terminal display status window (after "/") whether the vertical height of the row corresponds to the height of the font selected.
5. Get back to the **PRINTING PARAMETERS** command to view the **Cnv spd m/min** parameter.
6. Hold down the  key and check the maximum possible setting of the **Cnv spd m/min** parameter. **This is the maximum print rate value for the given font, print parameters Intensity, Resol.dot/dcm and others.**



**NOTE:**

- The above procedure can only be applied when timing pulses are generated by an internal generator (not the shaft-encoder). When the shaft-encoder is used, the print rate cannot be controlled automatically as the control program has no impact on frequency of pulses from the shaft-encoder.
- In order to determine an image resolution (a number of characters per decimetre or characters per inch) use the following formula:

$$R_{\text{ch/dm}} = \frac{R_{\text{dots/dm}}}{\text{CHARACTER WIDTH} + \text{DISTANCE}} \quad \left| \quad R_{\text{ch/in}} = \frac{0,254 * R_{\text{dots/dm}}}{\text{CHARACTER WIDTH} + \text{DISTANCE}}$$

where:

- R<sub>ch/dm</sub>** - an image resolution (a number of characters per decimetre),
- R<sub>ch/in</sub>** - an image resolution (a number of characters per inch),
- R<sub>dots/dm</sub>** - an image resolution (a number of dots per decimetre); it is the same as the setting of the **Resol.dot/dcm** parameter,

**CHARACTER WIDTH** - a width (a number of dots) of a character for the given font,  
**DISTANCE** - a distance (a number of dots) between characters; it is defined by the subfile parameter Distance.

For example, if you select **Latin 16x10**, the character width is 10. If **Distance=2** and **Resol.dot/dcm=60**, the character resolution is **5 ch/dm** or **1,27 ch/inch**.



## 5. Examples of How to Operate the Printer

**NOTE:**

It has been assumed that the user has become familiar with the manual or has at least read Chapter [4 Operating the Printer](#).



### 5.1. How to Print the First Sample Text File?

This chapter contains a description of how to prepare for operation the **EBS-1500** Printer where one electromagnetic head is installed and how to print a simple text file. The example covers instructions of how to install a new machine, switch it on, set major parameters and print a text file that has been input via a terminal attached to the printer.

- 1) If the unit is installed by the Manufacturer or authorized service staff, this section can be omitted. Otherwise the procedure below needs to be followed to install the unit:



- Read section [2.1 Safety Requirements](#).
- Follow instructions given in section [2.3 Installing the unit](#).

- 2) Place the print head in a holder in such a position that nobody or nothing can be splashed with ink accidentally. Therefore at first the head should be positioned in such a way that a vessel can be placed beneath the nozzle plate.

**NOTE:** If a sound alarm occurs while the below specified procedure is followed, try to find the reason for the alarm by studying the indications.. Alarms, errors, and failures are described in section [4.5 Alarms, Errors and Indications](#).

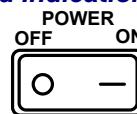

- 3) Switch the unit on by pressing the power switch to set it in the **ON** position - see section [3.1 Switching the Printer On](#). Check ink pressure on the ink pressure gauge. The pressure should meet requirements indicated in section [2.2 Power and Air Supply Requirements](#).

- 4) Create a text file using the terminal keypad.

In the main MENU select the **TEXT SERVICE** item and then the **CREATE NEW TEXT** item.

After the text file name, e.g. TXT1, has been specified, the text processor starts running. Now you can use the keypad to input what is to be printed. A description of the processor control keys is given in section [4.4.1.1 Introduction to Text Files](#), paragraph [WORD PROCESSOR – A Description of Control Keys](#).

	OVR	CAPS
COFFEEI		n=0525 p=12 s  12 int

Type the text ➤COFFEE◀ with terminal keys.

The text is shown on the terminal display. It looks the same as that on the real overprint provided that print parameters have been set correctly.

After the **ENTER** key has been pressed, the text file called **TXT1** and containing the word ➤COFFEE◀ is recorded in the file library and stored in the printer memory.

5) Set print parameters.

All options are normally preset by the Manufacturer to meet user requirements. Print parameters are set to their default<sup>6</sup> settings. The only important thing to make overprints is the source of timing pulses: a shaft-encoder (conveyor rate indicator) or an internal generator. If the print head is set to work with the shaft-encoder, it will make overprints only when the shaft-encoder axle rotates.

If the print head operation is timed by the internal generator, the overprints are made at a fixed rate no matter how fast the objects move (and even on stationary objects). The option can be set with the print parameter **Generator** to **GENERator** or **SHAFT**-encoder, as required.

In the main MENU select the **PRINTING** item and then the **PRINTING PARAMETERS** item.

For how to modify print parameters see section [4.4.3.4 Print Parameters](#).

The parameters should be set to the following values:

Parameter	Default setting:	REMARKS
<b>Vert. direct.</b>	<b>UP</b>	
<b>Space</b>	<b>2.0mm</b>	
<b>Text rpt.</b>	<b>1</b>	
<b>Rpt.dist.</b>	<b>30.0mm</b>	
<b>Direction</b>	<b>LEFT</b>	
<b>Height</b>	<b>20mm</b>	
<b>Offset</b>	<b>1</b>	
<b>Offset2</b>	<b>1</b>	
<b>Counter delta</b>	<b>1</b>	
<b>Row repetit.</b>	<b>1</b>	
<b>Intensity</b>	70	
<b>Generator</b>	!!!see above!!!	
<b>Resol.dot/dcm</b>	<b>60</b>	
<b>Cnv spd m/min or</b>	<b>10</b>	Only when <b>Generator=GEN</b> or
<b>Enc const p/m</b>	<b>10000</b>	Only when <b>Generator=SHAFT</b>
<b>No of Clean Strokes</b>	<b>0</b>	
<b>Clean. period (sec)</b>	<b>300</b>	

6) Start printing the text file called **TXT1** that was created previously.

In the main MENU select the **PRINTING** item and then the **START PRINT** item.

Printing starts after the name **TXT1** has been typed in and confirmed.

To stop printing, select the **STOP PRINTING** command in the **PRINTING** menu.

**NOTES:**



- Overprints are made each time the photodetector is activated after the **START PRINT** command has been selected. Objects or a sheet of paper should be placed in front of the print head at a minimal distance of 15 mm to ensure good print quality. If the photodetector operates properly, a red LED indicator lights up and goes out at the back of the photodetector. While conducting print tests, you can cover the photodetector with your hand for a while.
- After the photodetector has been activated, the printing starts. The procedure varies, however, according to the timing mode:

<sup>6</sup>Default value – a preliminary value defined by the Manufacturer.

- If the printing is timed by the internal generator, overprints are made no matter whether the object(s) move or not. If the object fails to move, a very narrow overprint is made and a single vertical row is printed only (!).
  - If the printing is timed by the shaft-encoder, overprints are made only when the shaft-encoder axle rotates.
- If the width of characters printed is incorrect, adjust the print rate following instructions given in section **4.6 Adjusting the Print Rate**.
- If the print rate is too fast, overprint quality tends to be poor. You can recognize it easily by discontinuous overprint as the print rate control system ignores some of the timing pulses. In effect the character width may get out of proportion. See also section **4.6 Adjusting the Print Rate**.

If the **STOP PRINTING** command has been selected during the printing, the current overprint is finished and the operation stops. In the event the shaft-encoder is used, this stage may take long (especially when long overprints are made and the shaft-encoder axle stops rotating after the conveyor has been stopped). Some commands may not be accepted then (and the message **CHANNEL ACTIVE** is shown on the display). To speed the process up, move the shaft-encoder axle a little to complete the overprint.

## 5.2. Creating and Printing Sample Text Files

### NOTE:

The following notation is used in the examples below:

- represents one space character,
- text< means text-file contents to be input via the terminal keypad.

### 5.2.1. How to Print the Current Date and Time?

**Assumption:** the printer is equipped with a 16 nozzle head; it is 25<sup>th</sup> July 2003, 10:34 hours; the overprint should look like as follows:

```
DATE: 25.07.03
TIME: 10:34
```

- 1) Define four **TEXT** type subfiles, with two of them being special registers **Date** and **Time**. See section **4.4.1.10 Using Special Registers**.
  - In the main MENU select the **TEXT SERVICE** item and then the **CREATE NEW TEXT** item.
  - You are asked to type a file name. Input a four-character file name, e.g. **DATI** and confirm.

Type	: Text
Char. set	: Latin 7x5
Typeface	: Normal
Distance	: 2
Rotation	: None
Spec.reg.	: None

- Set parameters for the first subfile (the **PAR** key) and confirm.
- Input contents for the first subfile: ➤DATE :□<.
- Press the **CTRL** **→** keys to create a new subfile on the right of the previous one.

Spec.reg.	: Date
-----------	--------

- Set parameters for the second subfile, as above, and change the setting for **Spec.reg.** and confirm.
- Input contents for the second subfile: ➤00.00.00<.
- Press the **CTRL** **↓** keys to create a new subfile below two previous ones.

Spec.reg. : None

- Set parameters for the third subfile, as above, change the setting for **Spec.reg.** and confirm.
- Input contents for the third subfile:     ➤TIME:□◀.
- Press the **CTRL** **→** keys to create a new subfile on the right of the previous one.

Spec.reg. : Time

- Set parameters for the fourth subfile, as above, change the setting for **Spec.reg.** and confirm.
- Input contents for the fourth subfile:     ➤00:00◀  
(hours and minutes only).
- Press the **ENTER** key to record the text file in the library and save it in the memory.

- 2) Define print parameters, as in section [5.1 How to Print the First Sample Text File?](#) item 5).
- 3) Print the text file called **DATI** - see section [5.1 How to Print the First Sample Text File?](#) item 6).

### 5.2.2. How to Print Consecutive Numbers?

**Assumption:** the printer is equipped with a 25 nozzle head and a six-digit number is to be printed; there is an object moving in front of the print head, it has been detected by the phtodetector as the 5824<sup>th</sup> in turn; the text should look like as follows, when printed (only the number changes in every overprint):

Serial number: 005824

- 1) Define two **TEXT** type subfiles, with one of them being a special register **Up counter**. See section [4.4.1.10 Using Special Registers](#).
  - In the main MENU select the **TEXT SERVICE** item and then the **CREATE NEW TEXT** item.
  - You are asked to type a file name. Input a four-character file name, e.g. **NUMR** and confirm.

Type : Text  
 Char. set : Latin 16x10  
 Typeface : Bold  
 Distance : 2  
 Rotation : None  
 Spec.reg. : None

- Set parameters for the first subfile (the **PAR** key) and confirm.
- Input contents for the first subfile:     ➤Serial□number:□◀.
- Press the **CTRL** **→** keys to create a new subfile on the right of the previous one.

Type : Text  
 Char. set : Latin 25x15  
 Typeface : Normal  
 Distance : 2  
 Rotation : None  
 Spec.reg. : Up counter

- Set parameters for the second subfile and confirm.
- Input contents for the second subfile:     ➤000001◀.
- Move the cursor to the first subfile position and move the first subfile to the second level with the **SHIFT** **↓** keys.
- Press the **ENTER** key to record the text file in the library and save it in the memory.

- 2) Define print parameters as in section [5.1 How to Print the First Sample Text File?](#) item 5).

- 3) Print the text file called **NUMR** - see section [5.1 How to Print the First Sample Text File?](#) item 6).

**NOTE:** The serial numbers will increase by one: 000001, 000002, 000003, ... , 000025, etc. with every overprint. While editing the second subfile you can set an initial number within the subfile to continue the counting with it.

### 5.2.3. How to Print Expiry Date?

**Assumption:** the printer is equipped with a 16 nozzle head; the product labelled is fit for use for 70 days; if the current date is 30<sup>th</sup> June 2004, the overprints would look like as follows:

**Best before: 08.09.04**

- 1) Define two **TEXT** type subfiles, with one of them being a special register **Date+offs.**. See section [4.4.1.10 Using Special Registers](#).

➔ In the main MENU select the **TEXT SERVICE** item and then the **CREATE NEW TEXT** item.

➔ You are asked to type a file name. Input a four-character file name, e.g. **EXDA** and press the **ENTER** key.

Type	: Text
Char. set	: Latin 9x5
Typeface	: Bold
Distance	: 2
Rotation	: None
Spec.reg.	: None

- Set parameters for the first subfile (the **PAR** key) and confirm.

- Input contents for the first subfile:  
 ➤Best□before:□◀.

- Press the **CTRL** **→** keys to create a new subfile on the right of the previous one.

Type	: Text
Char. set	: Latin 16x10
Typeface	: Normal
Distance	: 2
Rotation	: None
Spec.reg.	: Date+offs.

- Set parameters for the second subfile and confirm.

- Input contents for the second subfile: ➤DA.MO.YE◀.

**NOTE:** The file contains the date coded as **day.month.year.** - see section [4.4.1.10 Using Special Registers, universal date and time](#) register.

- Move the cursor to the first subfile position and move the first subfile to the second level with the **SHIFT** **↓** keys.

- Press the **ENTER** key to record the text file in the library and save it in the memory.

- 2) Define print parameters as in section [5.1 How to Print the First Sample Text File?](#) item 5) and set the **Offset** parameter to **70** (70 days).

- 3) Print the text file called **EXDA** - see section [5.1 How to Print the First Sample Text File?](#) item 6).

**NOTE:** The current date is increased by 70 days after every overprint has been made and the new date is printed then.

### 5.2.4. How to Print Logos?

**Assumption:** the printer is equipped with a 25 nozzle head; the overprint should look like as follows:



- 1) Define a **GRAPHIC** subfile and make a graphical image – a logo.
  - ➔ In the main MENU select the **TEXT SERVICE** item and then the **CREATE NEW TEXT** item.
  - ➔ You are asked to type a file name. Input a four-character file name, e.g. **LOGO** and confirm

Type	: Graphic
Height	: 25
Length	: 25
Front dis	: 5
Back dist	: 5

- Set parameters for the first subfile (the **PAR** key) and press the **ENTER** key.
- Press the **CTRL** **ENTER** keys to move to the graphic processor.
- Now develop a graphical image using appropriate function keys that are offered by the processor - see section [4.4.1.2 Opening and Editing a New File](#) paragraph **GRAPHIC PROCESSOR – A description of function keys** and confirm.

**NOTE:**

If you find it difficult to design a graphical image on the terminal display, you can make a drawing on a sheet of squared paper, and then copy it to the graphic processor - see [Fig. 5.2.4.1](#).

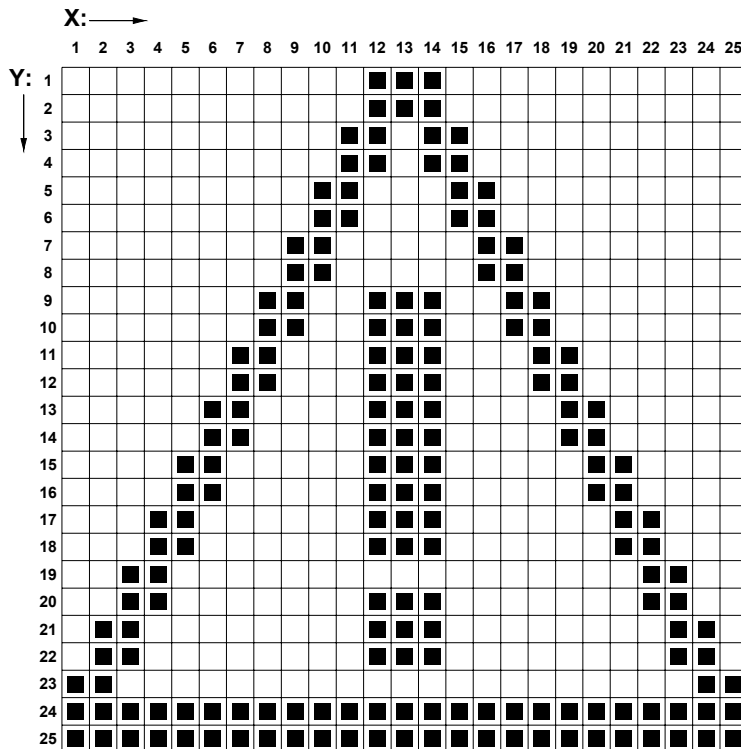

Fig. 5.2.4.1.

If the drawing is acceptable, press the **ENTER** key again in order to record the text file in the library and save it in the memory. If not, press the **CTRL** **ENTER** keys and go on with improving your drawing.

- 2) Define print parameters as in section [5.1 How to Print the First Sample Text File?](#) item 5).
- 3) Print the text file called **LOGO** - see section [5.1 How to Print the First Sample Text File?](#) item 6).

### 5.2.5. How to Print a Bar Code?

**Assumption:** the printer is equipped with a 25 nozzle head; a bar code should be printed on a lot of products; the overprint should look like as follows:



- 1) Define **BAR CODE** type subfile and specify a number code to form the bar code.
  - ➔ In the main MENU select the **TEXT SERVICE** item and then the **CREATE NEW TEXT** item.
  - ➔ You are asked to type a file name. Input a four-character file name, e.g. **BARC** and confirm.

Type	: Barcode
Code	: EAN-13
Contents	: 500746300621
Height	: 25
Elongat.X	: 1
Spec.reg.	: None
Front dis	: 0
Back dist	: 0
Signature	: YES
Inversion	: NO

- Set subfile parameters (the **PAR** key), input the numerical value of the bar code (only 12 characters, the 13<sup>th</sup> character is calculated automatically) and confirm.
- If the bar code is acceptable, press the **ENTER** key in order to record the text file in the library and save it in the memory. If not, press the **PAR** key again and go on with modifying the bar code and subfile parameters.

- 2) Define print parameters as in section [5.1 How to Print the First Sample Text File?](#) item 5).
- 3) Print the text file called **BARC** - see section [5.1 How to Print the First Sample Text File?](#) item 6).

### 5.2.6. How to Print a Complex Subfile?

**Assumption:** the printer is equipped with a 25 nozzle head; it is 25<sup>th</sup> July 2003, 10:34 hours; the text should look like as follows, when printed:

**EBS Ink-Jet Systems GmbH**          German Manufacturer of     DATE: 25.07.03  
 Alte Ziegelei 19-25, D-51588 Nümbrecht     **INK-JET**     Printers     TIME: 10:34

- 1) A complex file of this type can be created in three ways (!):
  - a) create each of the subfiles of your complex file separately, each of them having its own name, then start a new file and link all subfiles into it by their names,
  - b) create a text file and define the subfiles within it,
  - c) use a mixed method to create a text file in which some subfiles are defined and the other are linked by their names.

The mixed method is used in the example. The text files called **DATI** and **LOGO** have already been defined in paragraphs above and will be used in this example (they need to be created in advance to illustrate the methodology properly).



Define two **TEXT** type subfiles, link the graphical image called **LOGO** by its name, create three other **TEXT** type subfiles and link the text file called **DATI** where special registers are used.

➔ In the main MENU select the **TEXT SERVICE** item and then the **CREATE NEW TEXT** item.

➔ You are asked to type a file name. Input a four-character file name, e.g. **ABCD** and confirm.

Type	: Text
Char. set	: Latin 16x10
Typeface	: Normal
Distance	: 2
Rotation	: None
Spec.reg.	: None

- Set parameters for the first subfile (the **PAR** key) and press the **ENTER** key.
- Input contents for the first subfile:  
➤EBS□Ink-Jet Systems□GmbH◀.
- Press the **CTRL** **↓** keys to create a new subfile below the previous one.

Char. set	: Latin 7x5
Typeface	: Normal

- Set parameters for the second subfile as above, change the **Char. set** and **Typeface** parameters, and confirm.
- Input contents for the second subfile:  
➤Alte□Ziegelei□19-25,□D-51588□Nümbrecht◀.
- Press the **CTRL** **→** keys to create the third subfile on the right of the previous one.
- Using the **SHIFT** **↑** keys move the new created subfile as high upwards as possible.
- Set parameters for the subfile and confirm.

Type	: Ins. text
Text name	: LOGO
Front dis	: 0
Back dist	: 0

**NOTE:** The text file called **LOGO** has been defined in section **5.2.4 How to Print Logos?**

Type	: Text
Char. set	: Latin 7x5
Typeface	: Normal
Distance	: 2
Rotation	: None
Spec.reg.	: None

- Press the **CTRL** **→** keys to create the fourth subfile on the right of the previous one.
- Set parameters for the fourth subfile and confirm.
- Input contents for the fourth subfile:  
➤German□Manufacturer□of□◀.
- Press the **CTRL** **↓** keys to create the fifth subfile below the previous one and set the same parameters as for the fourth subfile, changing only the **Typeface** parameter.

Typeface	: Length *3
----------	-------------

- Input contents for the fifth subfile:  
➤INK-JET◀.
- Press the **CTRL** **↓** keys to create the sixth subfile below the previous one and set the same parameters as for the fifth subfile but change the **Typeface** parameter. Confirm the selection with the **ENTER** key.

Typeface	: Normal
----------	----------

- Input contents for the sixth subfile: ➤printers◀.
- Press the **CTRL** **→** keys to create the last seventh subfile on the right of the previous one.
- Using the **SHIFT** **↑** keys move the newly created subfile as high upwards as possible.



<b>Type</b>	: <b>Ins. text</b>
<b>Text name</b>	: <b>DATI</b>
<b>Front dis</b>	: <b>5</b>
<b>Back dist</b>	: <b>0</b>

- Set parameters for the subfile and confirm.

**NOTE:** The text file called **DATI** has been defined in section **5.2.1 How to Print the Current Date and Time?**.

- 2) Define print parameters as in section **5.1 How to Print the First Sample Text File?** item **5**).
- 3) Print the text file called **ABCD** - see section **5.1 How to Print the First Sample Text File?** item **6**).

## 6. Servicing and Maintenance of the Printer

### 6.1. Routine Maintenance

Before starting maintenance operations, study section [2.1 Safety Requirements](#).

User-performed maintenance covers, amongst other things, periodic inspections and service operations to keep the machine in good working order. Some operations need to be performed daily while others every specified period of time, or after a certain amount of ink is consumed.

Daily maintenance:

- Check ink level in the ink bottle. If the bottle is empty (the message: **INK LACK** or **EMPTY BOTTLE**. is shown on the terminal display), replace it. **In the systems with electromagnetic heads and the pump-based ink system, the ink bottle can be replaced while the printing operation is being performed. If a compressor system is used you need to stop the printing and depressurise the ink system - see section [2.3.5 Installing a new Bottle of Ink \(or Replacing an Empty One\)](#).**
- After the machine has been switched off - wash outer parts of the print head, especially the nozzles and photodetector in order to remove any remaining ink - see also section [3.2 Switching the Printer Off](#). Use a sprayer with solvent to do this.

Routine maintenance:

- **Once a week** (or more frequently, if required) – check the state of supply air filters (which remove water, oil etc.) and clean them,
- **Every 1000 hours** of operation - check the ink filter in the bottle. Use the **ACTIVITY TIME** command to check for how many hours the printer has run. The total number of run hours (hours:minutes) is displayed on the terminal. Replace the ink filter **every 12 months**.
- If the printer is not to be used for a longer time (over 2 weeks), secure the print heads as described in section [7.1 Storing the Printer](#).

#### NOTE!



- ☞ **The use of sharp tools or improper fluid (solvent) to clean and wash the head may result in damage that is not covered by the warranty!**
- ☞ **Ink and cleaning fluid (solvent) can only be used, if supplied by the printer Manufacturer!**



- ☞ **Different ink types must not be mixed!**

**THE FAILURE TO MEET THE ABOVE REQUIREMENTS SHALL RELEASE THE MANUFACTURER FROM ITS WARRANTY OBLIGATIONS.**

## 6.2. Removing Air from the Ink System

Transport, manipulations to the ink system, or other reasons may result in accumulation of air within the print head. In consequence ink drops are not jetted from some or all nozzles..

In order to remove air from the print head, follow the instructions below:

- a). Set the ink pressure to its rating value.
- b). Turn the nozzle outlets towards a dish (which can be used to wash the head, for example).
- c). Press the rinse key  at the sloping part of the head housing. This will open all electromagnets within the head to release air bubbles, which will flow out together with the pressurised ink.
- d). Continue the air removal process until regular and continuous ink jets start flowing out of each nozzle.

Release the rinse key .

## 6.3. Replacing the Ink Filter

In order to maintain the appropriate ink quality and purity, an ink filter is installed in the system. The filter is placed in the suction tube inside the ink bottle and should be replaced following the recommendations given in chapter [6.1 Routine Maintenance](#).

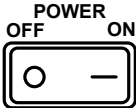

## 6.4. When Problems Arise while Operating or Servicing the Printer

<b>The printer does not switch on</b>	
<b>PROBLEM</b>	<b>REMEDY</b>
<p><b>After the main switch:</b></p> <div style="text-align: center;">  </div> <p>(on the right-hand side of the printer controller) has been turned on,</p> <p><b>the printer fails to switch on. The terminal display is not lit.</b></p>	<ul style="list-style-type: none"> <li>Check whether the outlet socket is energised.</li> <li>Check whether the power cord is plugged into the socket.</li> <li>Check whether the main switch (on the right-hand side of the printer controller) is in its <b>ON</b> position.</li> </ul> <p><b>NOTE:</b> Electronic protections are installed in the power supply in compliance with standards. There is no fuse that might be replaced by the user.</p>

### No overprints are made after the print command has been accepted

PROBLEM	REMEDY
<p>After the printer has been switched on and the <b>START PRINT</b> command selected and confirmed with the <b>**OK**</b> message, no overprints are made.</p>	<ul style="list-style-type: none"> <li>• Check whether the print head, photodetector and possibly the shaft-encoder are connected to the printer properly (cable connectors need to be plugged in and screwed tight in the controller and the head).</li> <li>• Check for proper settings of print parameters. If <b>Generator=SHAFT</b>, check whether the shaft-encoder axle rotates. If <b>Text rpt.</b> is not set to <b>CONTIN.</b>, check whether moving objects are detected by the photodetector.</li> <li>• Check whether the other print parameters are set properly.</li> <li>• Check whether the ink system components are connected properly, the ink system is pressurised, and there is some ink in the ink bottle.</li> </ul>

### Clogged nozzles in the head

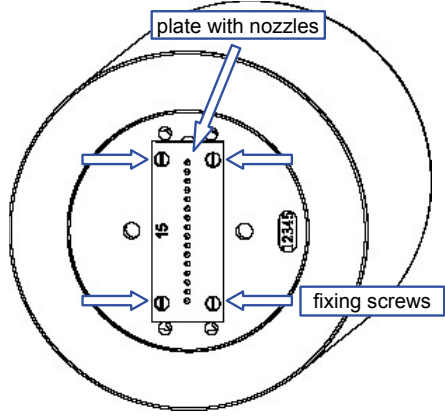
PROBLEM	REMEDY
<p>A nozzle is clogged. An attempt to clear it by rinsing does not help (to rinse the nozzle, press the  key at the back of the head housing - see section <a href="#">6.2 Removing Air from the Ink System</a>).</p>	<div style="text-align: center;">  </div> <p>Follow the instructions below:                      Cut the air pressure off and wait until the ink pressure drops down to zero.                      Remove the distance holder for packages from the front part of the head.</p>
	<p>Unscrew four fixing screws on the nozzle plate and remove the plate carefully.</p> <div style="text-align: center;">  </div> <p>If possible, wash the nozzle plate with solvent in ultrasonic bath. If the ultrasonic bath cannot be applied, leave the nozzle plate in solvent bath for about 10 minutes.                      Dry the plate with a tissue. Make sure no paper fibres are left.</p>

<b>Clogged nozzles in the head</b>	
<b>PROBLEM</b>	<b>REMEDY</b>
	<p>Clear the nozzles with a tungsten wire carefully from the back to the front (<b>The tungsten wire supplied by the manufacturer must be used only !!!</b>).</p> <p>Fasten the nozzle plate with screws taking care not to damage rubber gaskets or shutters.</p> <p>Install the slipper.</p> <p>Set the ink pressure to its rating value, switch the printer on, and remove air from the head system - see section <b>6.2 Removing Air from the Ink System</b>.</p>
	<p><b>NOTE:</b></p> <p>The above operations need to be performed under strictly clean conditions.</p> <p>Do not leave any foreign objects under the nozzle plate.</p> <p>If the plate is fastened improperly, the nozzles may get damaged (ruby tip may break).</p>

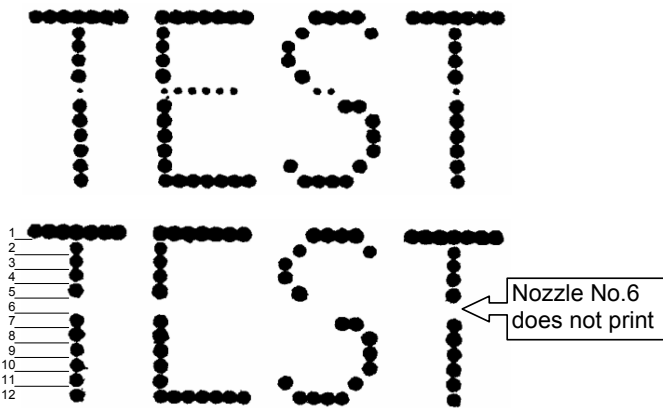
<b>Some dots are much smaller than others or are missing</b>	
<b>PROBLEM</b>	<b>REMEDY</b>
<p>All dots jetted out of a particular nozzle (a horizontal line) are much smaller than others or are missing.</p>	<div style="text-align: center;">  </div> <p>The solenoid valve corresponding to a faulty nozzle may be out of order. Try to adjust the valve electromagnet following the procedure below.</p>

### *Adjusting valve electromagnets in electromagnetic heads*

**NOTE:**  
 The procedure should be performed by trained staff authorised to service EBS Printers.



1. Remove the head housing – see section **2.4 Removing the Head Cover**.
2. Fix the head without the housing (a special service holder from the Manufacturer can be used). Place adsorbent cloth and a dish behind the head.
3. Create a sample text file (a graphic file would be the best). It should be 1-dot wide and as high as possible for the given head type.

4. Check whether the ink pressure is set to its rating value. The value of the rating pressure depends on the diameter of nozzles in the print head. The nozzle diameter is engraved on the nozzle plate.
5. Start continuous printing of a sample file (with **Text rpt.=CONTIN.**).
6. Move to the **SERVICE** menu and select the **OTHERS** command. Type a service password. Go to the **ADJUSTMENTS** menu, set **Intensity=170**. and indicate the nozzle to be adjusted with the **Set Nozzle no** parameter.
7. Insert a screwdriver for cross recessed screws (TORX-type wrench No. **T6** or a 0.035" stem wrench or IMBUS 0,035" for older types of print head) onto the adjusting screw whose number corresponds to that previously set with the **Set Nozzle no** parameter. Screw in the screw with the wrench until ink drops start flowing out of the nozzle under adjustment. Electromagnet numbers are marked on plastic bodies - see the illustration on the right.
8. While turning the wrench and moving a sheet of paper perpendicularly to the nozzle axis at a distance of 10mm, adjust the dot size as required. The dot must be round in shape with no satellites or splashes.
9. Adjust other nozzles as described at items 7, 8 above to get the same dot size for all nozzles.
10. On adjusting the last nozzle, turn them all on at the same time (**Set Nozzle no=All**) and while turning the consecutive adjusting screws clockwise or counter-clockwise (maximum ¼ of the rotation) shape all dots so that they are all of a similar size.
11. Reduce ink drop intensity to **50** (with the parameter **Intensity=50**) and improve the adjustment by following steps 8, 9 and 10.
12. Exit the **ADJUSTMENTS** menu and stop the printing.
13. Check what the deflection of the ink jet from the nozzle axis is. To do this, observe ink jets on

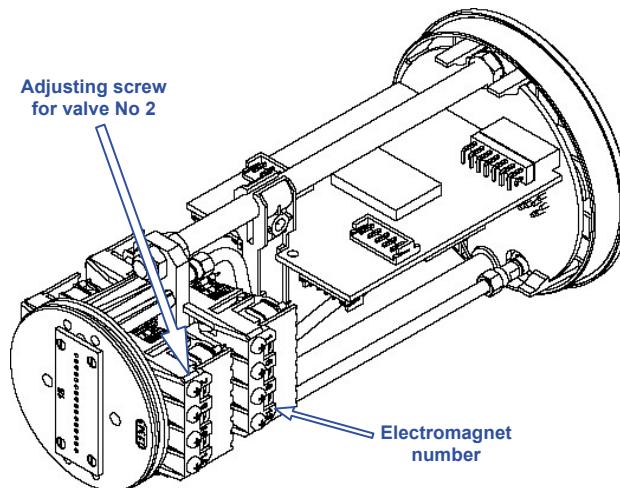

a light background with the rinse key  on. The ink jets must not be either deflected from the axis by more than 2mm on the horizontal and vertical planes or crossed, when they are at a distance of 60÷80mm from the front of the head and jetted at the rated ink pressure. If this requirement is not met, clean the nozzles. If this does not help, replace the nozzle plate and perform steps 6 to 12 of the adjustment procedure again. Should no positive results be obtained after the replacement, check for proper installation of flexible connectors and electromagnet units or get the print head repaired.

14. After the solenoid valves have been adjusted, reinstall the housing and place the head in the head holder in its working position.

The first overprint below is made after electromagnets have been adjusted properly. The other overprints are made when the electromagnet for nozzle No. 6 is out of order. The improper adjustment is presented on the clock face, where one full rotation is 60 minutes.



Electromagnets are **adjusted properly**



Adjusting screw is turned **10 minutes counterclockwise**



Adjusting screw is turned **15 minutes counterclockwise**



Adjusting screw is turned **15 minutes clockwise**

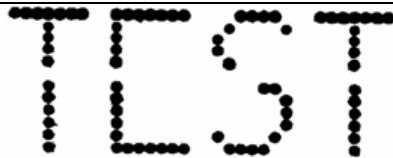

Adjusting screw is turned **20 minutes clockwise**

### Overprints are distorted

#### PROBLEM

#### REMEDY

1. Overprints are distorted. There are irregular ink splashes or ink dots overlap each other as shown in the example on the right.

When the print head is hit by a moving object, it may get repositioned. See the example below:



Such overprints are made when the distance between the print head and the object is too big. Move the head to the object plane at the distance of less than **15mm**. If this is impossible, adjust electromagnets within the head to print over a greater distance - see paragraph *Adjusting valve electromagnets in electromagnetic heads* above. Overprints made at different distances between the front of the head and objects are shown below.

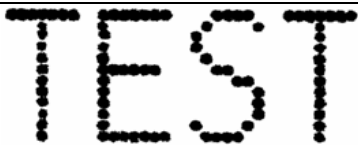





The distance between the head and object is **6 mm**,

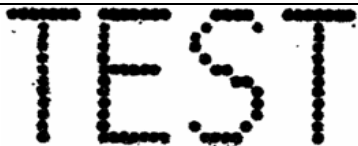



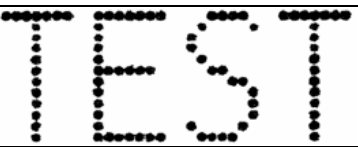
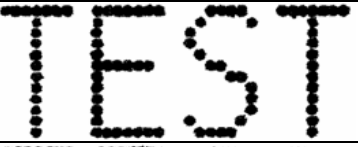

The distance between the head and object is **10 mm**,



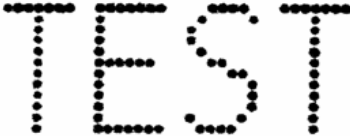

The distance between the head and object is **15 mm**,

<b>Overprints are distorted</b>	
PROBLEM	REMEDY
	<p>The distance between the head and object is <b>20 mm</b>,</p>
<p>2. Overprints are distorted. Colour intensity is too high, drops are irregular, there are ink splashes around the overprint or ink dots overlap each other as in the example on the right.</p>	 <p>This happens when the ink pressure is too high (the pressure is set with a pressure regulator at the ink bottle container). Set the pressure to its rating value. See paragraph <b>2.3.4 Connections - Connecting the head to the ink and compressed air systems</b>. Overprints made at different ink pressures are shown below.</p>
	<p>Ink pressure is <b>0.2bar</b></p>
	<p>Ink pressure is <b>0.4bar</b></p>
	<p>Ink pressure is <b>0.6bar</b></p>
	<p>Ink pressure is <b>0.7bar</b></p>

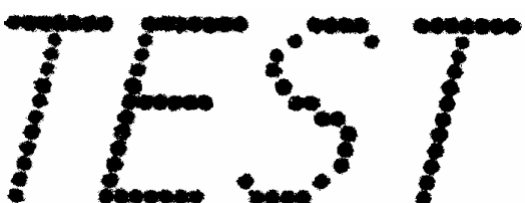

Overprints made with the electromagnetic head look like printed in bold and blurred	
PROBLEM	REMEDY
The overprint is saturated with ink, ink drops mingle and the overprint spreads over the object.	 <p>Overprints like this one occur when the print parameter <b>Intensity</b> is set too high. Overprints below are made at the rated pressure and different settings of the <b>Intensity</b> parameter.</p>
	Intensity=50
	Intensity=70
	Intensity=100
	Intensity=200

Overprints are slanted	
PROBLEM	REMEDY
Overprints are slanted to the left or right.	 <p>Such overprints are made with the print head turned around its own axis. Position the print head properly by turning it in the head holder in such a way that all nozzles are aligned in the vertical direction.</p>

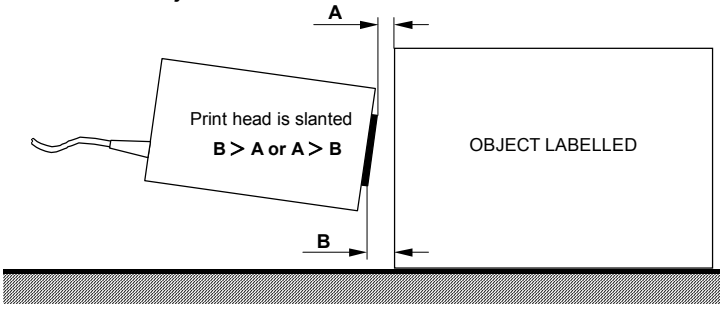
<b>Lower (upper) parts of overprints are distorted</b>	
PROBLEM	REMEDY
<p>Lower (upper) parts of overprints are distorted. Irregular ink splashes occur.</p>	<div style="text-align: center;">  </div> <p>Such overprints are made when the front of the print head is slanted down (up) and therefore lower (upper) nozzle outlets are more distant from the object than the other ones.</p> <div style="text-align: center;">  </div> <p>Level the print head by adjusting the head holder.</p>

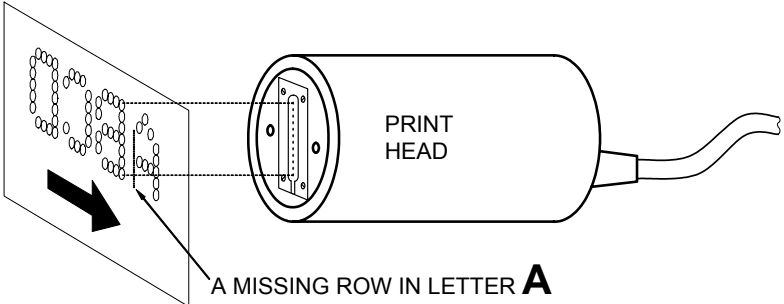
<b>Some vertical rows are missing in overprints</b>	
PROBLEM	REMEDY
<p>Some vertical rows are missing in overprints (this relates to the printers where the printing of vertical rows is timed by an external shaft-encoder).</p>	<div style="text-align: center;">  </div> <p>Such overprints are made when the print rate is too high in the printers where the printing is timed by an external shaft-encoder (strictly speaking, the timing frequency is too high).                      Reduce the setting for <b>Enc const p/m</b> or <b>Resol.dot/dcm</b> in the <b>PRINTING PARAMETERS</b> command - see section <a href="#">4.6 Adjusting the Print Rate</a>.</p>

<b>Overprints are not straight, they are wavy or jagged</b>	
PROBLEM	REMEDY
<p>Overprints are wavy or jagged.</p>	<ul style="list-style-type: none"> <li>➤ The head holder is fixed to the base that is subject to strong vibration and shocks. The head shakes during the printing. Fix the head holder to something more stable, that is not subject to vibration or shocks.</li> <li>➤ Objects moving on the conveyor belt are subject to strong vibration or shocks. The objects should not vibrate or shake at the moment overprints are made on them.</li> </ul>
	

<b>Mixed text names in the library – the battery is discharged</b>	
PROBLEM	REMEDY
<p>The following message appears on the terminal:</p> <p><b>BATTERY DISCHARGED !!!</b>  <b>- MEMORY DAMAGED !!!</b></p> <p>Names and contents of texts in the text library are mixed.</p>	<p>All or some cells of the printer's random-access memory where user-defined text names and contents are stored have been deleted for the following reasons:</p> <ul style="list-style-type: none"> <li>• The battery has discharged and the memory is not power supplied.</li> <li>• Strong interference might have occurred and changed the contents of the memory.</li> </ul> <p>After the discharged battery has been detected by the program and the printer has been switched on again, the following events will take place:</p> <ul style="list-style-type: none"> <li>• The language selected by a user for communication with the printer is switched into English,</li> <li>• The message: <b>BATTERY DISCHARGED !!!</b>  <b>- MEMORY DAMAGED !!!</b> is displayed,</li> <li>• The printer's operation time is reset,</li> <li>• The current date is set to <b>01.01.00</b>,</li> <li>• The current time is set to <b>00:00</b>,</li> <li>• The ink validity date is set to <b>01.01.00</b>,</li> <li>• The printer identifier and possibly the operation-time limit are retained,</li> <li>• All information contained in RAM (texts, parameters and the current system data) is damaged, destroyed or at least dubious,</li> <li>• A new bottle of ink will be required by the printer with a <b>BOTTLE ALREADY CANCELLED</b> message. Another message can also be displayed, if the bottle had been replaced before the printer is switched on.</li> </ul> <p>Select the <i>clear memory</i> service command and define text files again using the word processor.</p>

## 6.5. How to contact your service representative?

The above paragraphs provide instructions on how to remove some printer faults. The faults can be corrected by the user without a need to call a service representative. In certain circumstances, however, any intervention by a service representative is not only desirable but necessary. Therefore before you call your service representative, collect some information to facilitate initial assessment of the fault. With this information your service representative can decide whether the printer has been operated improperly or some other fault has occurred. It also enables the service staff to prepare the visit to make this as efficient as possible.

When reporting a printer failure, be ready to give the following information:

1. Type of the printer.
2. Type of the fault and after-effects.
3. Printer status at the time of failure:
  - printer status displayed on the terminal (see section **4.3 Print Head Status**),
  - current settings for print parameters displayed on the terminal after the **PRINTING PARAMETERS** command has been selected,
  - optional, non-standard equipment installed, if any.
  - the history of errors available with the **READ ERRORS REPORT** command,
  - version numbers of control programs that are available on selecting the **OPTIONS** command,
  - ink, solvent and printer parameters available via the Ink Monitoring System (**IMS**) in the printer - the **PRINTER/INK TYPE** command.
4. What operations were being performed when the failure occurred.
5. Types and contents of subfiles of the entire text file printed, the overprint height (5, 7, 12, 16, 25, 32 or 64 dots).

The above information should be reported by telephone or faxed to your service representative.

### **NOTE:**

Contact a service representative that is recommended by the local distributor. Only authorised service staff are able to offer you professional and prompt assistance whenever you find the printer operation unsatisfactory.

## 7. Storage and Transportation

### 7.1. Storing the Printer

Allowable climatic and mechanical exposure:

- Storage temperature **from -5°C to +50°C**,
- Relative humidity **max. 90% without condensation**,
- Shocks: **max. 1 g, max 2ms**.

#### 1. The Printer Controller

All user-defined text files and parameter blocks, and also other settings such as time, date, counters, etc. are stored in the printer memory. The memory is energised with a battery after the power supply has been switched off. The battery capacity is sufficient to maintain the memory for **about 1 month** after the mains has been switched off. After that time the Manufacturer cannot guarantee that the memory contents are maintained as the battery capacities vary according to the set. If the printer is not to be used for more than 1 month, connect the controller to the mains and leave it for about 5 hours to recharge the battery.

Detach the controller from the mains by removing the power cord plug out of the outlet socket for storage. In addition, protect the machine against dust, exposure to aggressive vapours and gases and weather conditions.

#### 2. Electromagnetic Head

Parts of the electromagnetic head system are filled with ink. If the head is stored unprotected for some time, ink may dry inside the system and choke nozzles and valves. If the electromagnetic head is to be out of service for **over 3 weeks**, secure it in the following way:

- a). Install a bottle of solvent in place of the bottle of ink (the solvent should be suitable for the type of ink used).
- b). Turn the nozzle outlets towards a waste dish.
- c). Rinse the print head by pressing the rinse key  at the back of the head housing. Continue the rinsing until ink is completely replaced with solvent. Do not remove the solvent from the head or piping.
- d). Reduce the air pressure to zero.
- e). Detach the ink (solvent) pipe with a non-return valve on it from the ink inlet connector (the non-return valve protects ink from pouring out of the pipe and head).
- f). Wash with solvent the front part of the print head (the nozzle plate) and valve sockets within the head connectors. Screw gland nuts on connector adapters within the head.
- g). Protect the print head against dust, exposure to aggressive vapours and gases and weather conditions. The best way would be to put the head into a polyethylene bag, remove air from the bag, and close the bag tight. Protect the head against mechanical damage.

**NOTE:**

**The heads must be filled with solvent for storage. The solvent does not contain water, prevents condensation of steam, and protects against corrosion. Only solvent recommended by the Manufacturer and suitable for the ink type should be used.**



## 7.2. Transporting the Printer

The printer should be transported in its regular working position. Avoid any excessive shocks or vibration.

If there is a threat that the printing system (the controller, print head, ink system) may get tilted or be exposed to excessive shocks or vibration during the transportation, secure the unit in the following way:

1. Detach and remove the printer from its workplace.
2. Remove the bottle of ink and plug it with a cap to protect the ink from pouring out.
3. Remove the print head, ink system and connecting cables.
4. Protect the print head as for storage - see section [7.1 Storing the Printer](#)
5. Wrap the printing system components (the controller, print head, ink system container, container and head fixtures and holders) with corrugated board or bubble foil - see [Fig. 7.2.1](#)
6. Wind up connecting cables and polyethylene piping to make a reel diameter of about 20cm and secure with packing tape.

Place all secured parts in a cardboard box (the original transportation packing is recommended) and protect them against moving inside the box. Close the box and protect it from getting open accidentally. You can also use other packing to protect all parts against mechanical damage. Allowable mechanical shocks inside the packing must not exceed **max 1g, max 2ms**.



Fig. 7.2.1.

**NOTE:**

The above procedure applies to the compressor-based printing system. The elements of a printing system a the pump-based ink system are described in the document entitled *Ink System with an Ink Pump*.

## 8. Multi-head Ink-Jet Printers

Considering label creation methods and materials to be labeled, the multi-head **INK-JET** printers have the same applications as single-head printers have. In terms of complexity, we should talk about a printing system instead of a simple printer.

The multi-head systems are based on the series of **EBS-1500** single-head printers. Each print-head can print a label independently from the other on an object (or a few objects) moving on a factory conveyor.

A description of multi-head printing systems is contained in a separate document.



## 9. Technical Specifications

### 1. Technical Data for the Printer (mainly controller)

- **Number of heads** 1 or 2 dependant<sup>(7\*)</sup>, for 1-2 print head UPC EBS-1501(2) controllers,  
1 up to 6 dependant(\*), for 1-6 print head UPC EBS-1506 controllers.
- **Length of cable between the controller and print head** normally **3m**, max. **40m** for one 12-nozzle head ,
- **Character size** matrices: 5x5, 7x5 9x5, 9x7, 11x8, 12x6, 12x7, 14x9, 16x10, 16x14, 25x15, 21x15, 32x18, 64x36, (restricted by the type of print head used, i.e. by the maximum row height)
- **Any combination of font types and sizes** (up to the maximum row height),
- **Bold face printing and an option to increase character thickness** up to **15** times,
- **Graphic images of any length** and as high as the maximum row height, to be **inserted at any place of the text file to be printed**,
- **A diversity of types of bar code** and the optional **ECC-200 Data Matrix** (2D code, two-dimensional matrix symbology),
- **The text file length** limited by the **256kB** memory capacity, with the maximum number of text files of **1024** (up to 2000 on request),
- **A terminal and other service interfaces** (for component parts of the printer refer to section **2.3.1 Printer accessories**):
  - a) A **built-in terminal** equipped with a splash-proof alphanumerical keyboard and an LCD display as standard.
  - b) The built-in terminal can optionally be accompanied by an external **personal computer** (PC) which ensures the following:
    - controls the operation of a single printer via the **EdGraf** program and an **RS-232** interface with automatic negotiation of the transmission rate of 9600 Bd or 19200 Bd, for up to 10 m-long cables, or an optional **RS-485** interface for longer connecting cables,
    - controls remotely a network of **EBS** printers of various types via the **InkNet** program and an **RS-485** interface for the transmission rate of 19200 Bd.
  - c) **An additional transmission interface** (a so called special channel - option) whose specifications are consistent with those of the **RS 232** interface, for transmission rates of up to **38.4 kBd**.
- **Rotation-to-pulse converter** (shaft-encoder - option) to be used with factory conveyors of varying feed rates,
- **Power supply** **100-240V/45-440Hz AC** or **90-350V DC**,
- **Power consumption** **10W** (in the **stop** mode, without the print head, for UPC EBS-1501(2) controller),  
**15 W** (in the **stop** mode, without the print head, for UPC EBS-1506 controller)
- **Working conditions**  
Air temperature at the workplace: normally between **+5°C** and **+40°C**,  
Relative humidity: **< 90%** without steam condensation.

<sup>7</sup> **Two print heads are dependant** when the printing is released by a single common photo detector and timed with a single common internal generator or external shaft-encoder for both print heads at the same time



- **Mechanical hazard** vibration: < **1g** at the frequency of < **10Hz**,  
shocks: < **1g** for the maximum of **2ms**,
- **Weight** **3350 g** (UPC EBS-1501(2) controller with power supply cord),  
**3770 g** (UPC EBS-1506 controller with power supply cord),  
**255 g** (3m long cable)
- **Dimensions** height: **95mm**,  
width: **300mm**,  
length: **237mm** for UPC EBS-1501(2) controller,  
**300 mm** for UPC EBS-1506 controller.

## 2. Technical data for the electromagnetic print head

- 
- **Number of dots (nozzles)**, i.e. max. row height **5, 7, 12, 16, 25, 32, 64** nozzles,
- **Dot diameter** **0.85 mm** (for a 120µm. nozzle),
- **Maximum distance between dots in vertical direction** **1,8 mm**,
- **Character height** **6 ÷ MAX mm**, where:  
MAX = (number of nozzles) \* 1,8 mm
- **Height adjustment** by turning the print head,
- **Distance between objects and the head** **2 ÷ 20 mm**,
- **Head position during the printing** any,
- **Ink type** spirit- or MEK-based
- **Ink consumption** a. **25 ml/h.** (intensity=70, working pressure =0.4 bar, feed=10m/min, letters and digits),
- **Air temperature at the workplace** normally **from +5°C to +40°C**
- **Compressed air** (if a compressor system is used), free from impurities  
Regulator upstream (inlet) pressure: **1 ÷ 10 bar**,  
Regulator downstream (outlet) pressure -working pressure: **0.2 ÷ 0.5 bar**, not more than **1 bar**,  
A possibility of using a pump-based ink system
- **Current input** (UPC EBS-1501(2) controller with maximum load): **0,51 A** (at rated voltage of 100 V) - **0,22 A** (at rated voltage of 240 V).

### NOTE:

- a). The maximum current input of the printing system depends on the following:
  - the number and type of print-heads (number of nozzles),
  - the print rate and intensity,
  - the fill ratio, that is the proportion of the number of dots actually printed to the maximum number of dots resulting from the multiplication of the text length (the number of rows) by the maximal text height.
- b). Current consumed by the print head(s) must not exceed the capacity of the power supply of a 24V controller, which is:
  - 1,5 A** for 1-2 head controller,
  - 5 A** for a 1-6 head controller.



- **Dimensions**
  - diameter: **70 mm**, for 7 to 16-nozzle print head,  
**90 mm**, for 25 and 32-nozzle print head.
  - length: **148 mm**.
- **Weight**
  - 7-nozzle print head: **826 g**,
  - 12-nozzle print head: **835 g**,
  - 16-nozzle print head: **873 g**,
  - 25-noozle print head **1067 g**,
  - 32-nozzle print head: **1113 g**,
  - 64-nozzle print head: **1820 g**.

### **3. Functions and features that guarantee high comfort of operation and service**

- automatic diagnosis of errors and failures, for example detection of no ink in the ink bottle,
- controlling the operation of external devices (e.g. stopping the conveyor) to follow the printer status (e.g. no ink error),
- the printer design and software are able to accommodate a greater number of fonts, special text files and to ensure the operation of a network of printers, which are linked into a PC-type host computer,
- all external connectors are located on one housing wall to enable the user to position the printer in a corner of the room.

## Appendix A - Layout of Cyrillic Characters on the Printer Terminal Keypad

The layout of **Cyrillic** on the keypad of the printer terminal is shown in the picture below. The characters are available after the subtext type has been set to Text in the processor parameters and the character matrix (the **Char. set** parameter) to that whose name starts with “**Cyryl**”.

The Cyrillic characters marked on the keypad in blue are available at once. The Cyrillic characters shown in red are available after the **[ALT]** key has been pressed at first. Lower/upper case letters are available according to the position of the **[CAPS]** and **[SHIFT]** keys.

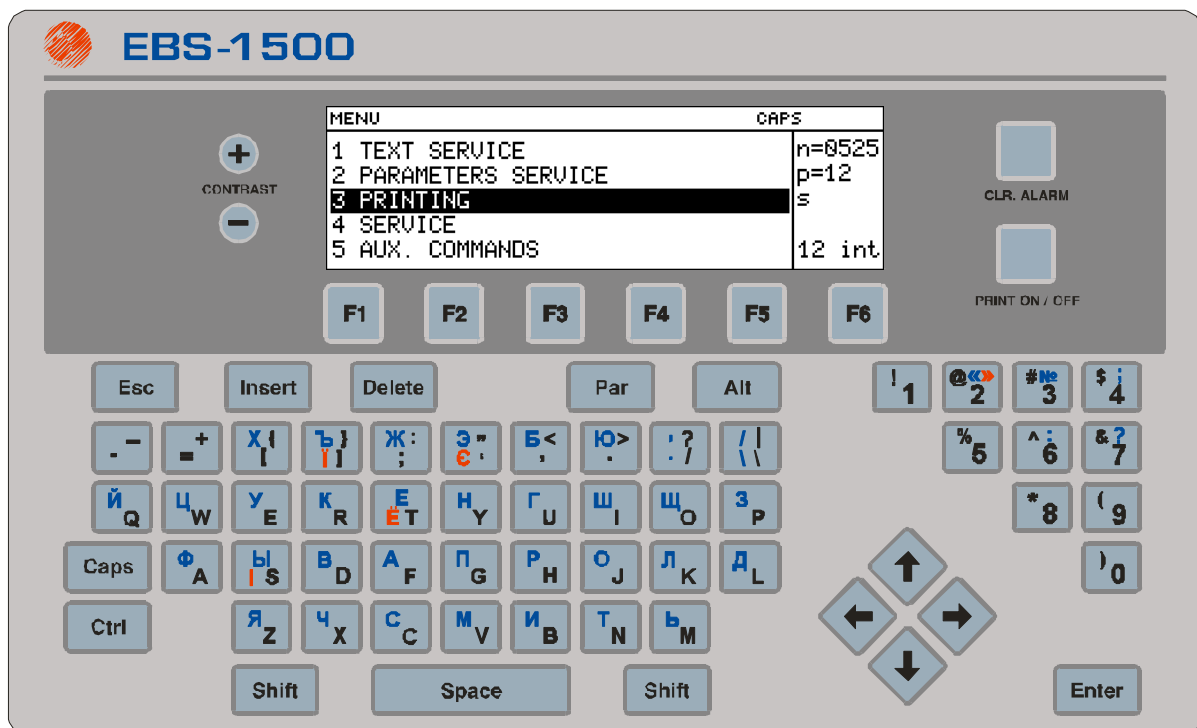

## Appendix B - Layout of Arabic Characters on the Printer Terminal Keypad

The layout of **Arabic** on the keypad of the printer terminal is shown in the picture below. The characters are available after the subtext type has been set to Text in the processor parameters and the character matrix (the **Char. set** parameter) to that whose name starts with “**Arabic**”.

Then the Arabic characters that are marked black on the keyboard are available right away. The Arabic characters marked red are available after the **SHIFT** key has been pressed, whereas the characters marked blue are available after the **ALT** key has been pressed.

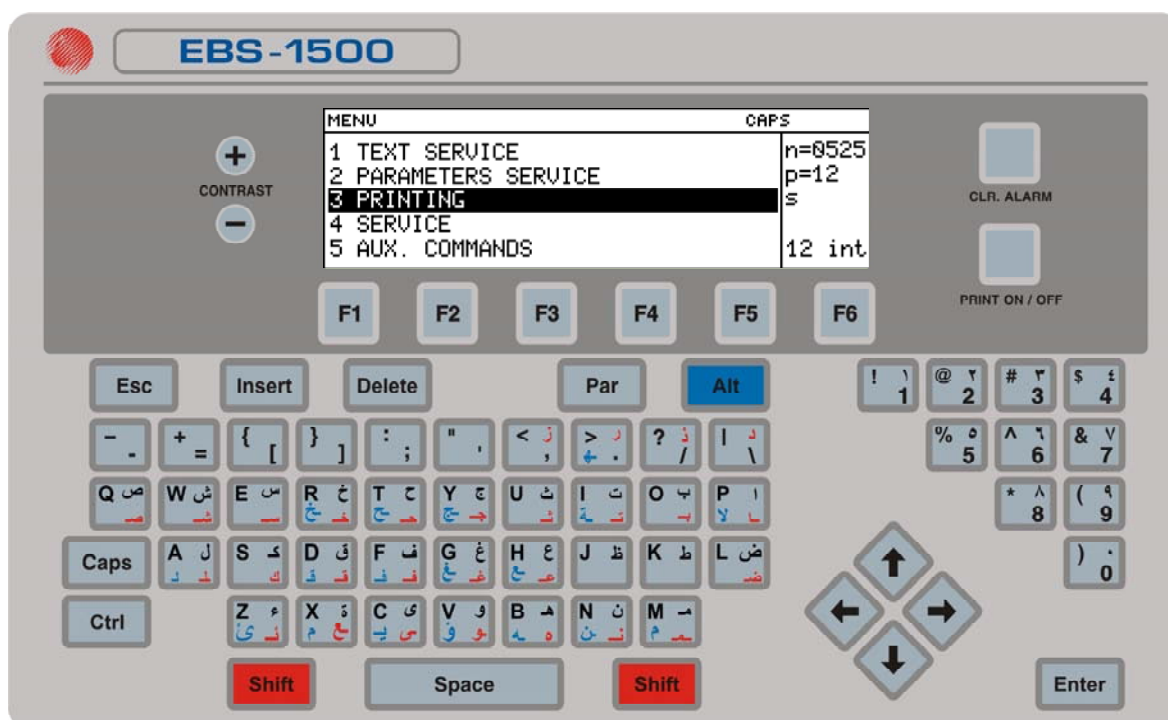

## Index

---

### A

air supply.....12, 15, 18, 79  
*air pressure* ..... 12, 16, 90, 99

alarm ..... 13, 21, 65, 70, 73, 75, 79  
*clearing* .....21, 70, 73, 75

ASCII.....*see* SUBFILE >> TEXT  
 ASCII CHARACTERS

---

### B

bar code ..... *see* SUBFILE >> BAR CODE

---

### C

code switch .....13, 63  
*emulated code switch* ..... 63

connections .....14, 15, 94

control panel ..... *see* OPERATION PANEL

controller.....7, 8, 9, 12, 13, 14, 15, 16,  
 20, 26, 65, 89, 90, 99, 100, 102, 103

counter.....*see* SPECIAL REGISTER  
 >> COUNTER

CS .....*see* CODE SWITCH

---

### D

display.....20, 22, 23, 27, 29, 31, 32,  
 35, 36, 37, 38, 39, 50, 51, 52, 61, 62, 63, 65,  
 74, 81

*graphic display*.....21, 22, 23, 26, 32, 63, 64,  
 68, 71, 78, 79, 84, 88, 89, 102

*window* ..... 22, 26, 36, 51, 65

*main window*.....22, 23, 27, 36,  
 51, 66, 67, 68, 71, 73

*status window* ..... 26, 32, 73

*printer status window*..... 22, 26, 68, 69

*terminal status window* ..... 22, 28, 32, 78

*internal display (LED)*..... 80

*terminal display*.....*see* DISPLAY >>  
 GRAPHIC DISPLAY

---

### E

EBS-6000 ..... 65

elektromagnet..... 89, 91, 92, 93

encoder.....*see* GENERATOR >>  
 SHAFT-ENCODER

Encoder constant.....*see* PRINTING >> PRINT  
 PARAMETERS >> ENCODER CONSTANT

---

### F

font .....*see* MATRIX

---

### G

generator.....31, 53, 54, 55, 56, 59,  
 64, 75, 76, 78, 80, 81, 90, 102

*character generator* ..... *see* MATRIX

*Shaft-encoder*.....13, 15, 16, 53, 59, 60, 64,  
 75, 76, 77, 78, 80, 81, 90, 96, 102

---

### H

head

*electromagnetic head*.....6, 8, 10,  
 13, 14, 16, 19, 57, 70, 78, 79, 88, 91, 93,  
 95, 99

*head cover*..... 15, 19, 91

*head gun* ..... 13

*head nozzle*.....8, 10, 18,  
 20, 26, 53, 57, 58, 60, 61, 65, 79, 81, 82,  
 83, 84, 85, 88, 89, 90, 91, 92, 95, 96, 99,  
 102, 103, 104

*head status*..... 22, 26, 98

*piezoceramic head* ..... 9

---

### I

IMS .....*see* INK MONITORING  
 SYSTEM

ink

*ink filter*..... 16, 19, 88, 89

*ink pressure*..... 18, 69, 79, 89, 90, 91, 92, 94

Ink Monitoring System.....13, 14, 16,  
68, 70, 71, 72, 73, 74, 98

## K

key

*control key*.....22, 29, 35, 79

*function key*.....21, 27, 32, 84

keypad.....9, 22, 23, 28,  
29, 43, 45, 46, 47, 49, 54, 63, 79, 81, 102, 105,  
106

## M

matrix .....29, 31, 78, 102, 104, 105, 106

## O

operation panel .....21, 52

## P

parameter block library.....see *PRINTING >> PRINT PARAMETERS >> BLOCK PARAMETER >> LIBRARY*

password.....27, 36, 37, 38, 39,  
48, 51, 62, 63, 64, 65, 67, 71, 92

photodetector.....10, 13, 14, 15, 39,  
41, 42, 55, 62, 63, 64, 80, 88, 90, 102

power supply.....11, 12, 28, 37, 49,  
65, 68, 89, 99, 102, 103

pressure.....10, 12, 14, 16, 17,  
18, 19, 20, 58, 69, 79, 92, 94, 95, 103

printer

*multi-head printer*..... 101

*single-head printer* ..... 101

*switching off*.....20, 88

*regular mode*..... 53

*switching on* .....20, 79

printing

*print parameters*..... 18, 37, 50, 53, 54,  
58, 59, 60, 61, 64, 75, 76, 77, 78, 79, 80,  
82, 83, 85, 87, 90, 95, 98

*block parameter* ..... 36, 37, 48, 49, 50, 53

*library* ..... 37, 50, 51, 53, 61

*Character Resolution* ..... 53, 59

*Conveyor Travel Speed* .... 53, 60, 64, 75, 76, 77

*Counter Increment* ..... 53, 58

*Date Offset*..... 53, 58

*Distance Between Overprints*..... 53, 56

*Encoder Constant* ..... 55, 56, 60, 64, 77

*Horizontal Direction*..... 53, 56

*Initial Distance* ..... 53, 55

*Ink Drop Intensity* ..... 53, 59, 92

*Number of Repetitions* ..... 53, 55

*Overprint Height* ..... 26, 53, 57, 58, 98

*Print Rate* ..... 59, 60, 75, 78, 81, 96

*Row Repetition*..... 53, 58

*Timing Mode* ..... 53, 59

*Vertical Direction* ..... 53, 55

## S

Shaft-encoder.....see *GENERATOR >> SHAFT-ENCODER*

solenoid ..... see *VALVE >> ELECTROVALVE*

solvent..... 9, 11, 20, 88, 90, 98, 99

special channel..... 10, 14, 48, 102

special register.....28, 31, 33, 39, 40, 41,  
42, 43, 45, 46, 47, 48, 58, 64, 81, 82, 83, 86

*counter*.....10, 31, 33, 39, 40, 41,  
42, 43, 44, 45, 58, 62, 63, 82, 92, 99

*Object Counters* ..... 33, 37, 39, 40, 62, 63

*change counter*..... 62, 63

*decremental counter* ..... 9, 39, 40, 58

*global counter*..... 62, 63

*incremental counter*..... 39, 40, 58

*Universal Counter* ..... 41, 42, 43, 45

*auxiliary counter* ..... 41, 42, 44

*main counter*..... 41, 42, 44

*Data from Special Channel*..... 48

*Date and Time*..... 40, 65, 81, 87

*Expiry Date Registers*..... 47

*Universal Date and Time* ..... 46

speed indicator ..... 13, 16, 60

subfile.....28, 29, 31,  
32, 33, 34, 35, 39, 40, 41, 47, 48, 49, 50, 52,  
53, 55, 57, 58, 78, 81, 82, 83, 84, 85, 86, 87,  
98

*bar code9*, 28, 31, 32, 33, 34, 35, 40, 48, 85,  
102

*bar code block*..... 33, 34

*graphic subfile* ..... 31, 32

*graphic block*..... 32

*Text - ASCII characters* ..... 28, 29, 39

*Text file name*..... 34

system

*electromagnetic-head system*..... 99

*ink system*..... 11, 12,  
13, 14, 15, 16, 18, 19, 20, 68, 70, 71, 73,  
74, 88, 89, 90, 91, 100, 103

*multi-head system* ..... 6, 101

printing system.....7, 12, 13,  
68, 73, 100, 101, 103

---

**T**

text

complex text file ..... 28  
simple text file .....28, 29, 79  
text file library.....27, 35, 36, 37, 47, 52, 79

transponder ..... 19, 20, 68, 70, 73, 74

---

**V**

valve ..... 8, 10, 17, 19, 20, 91, 93, 99  
electrovalve ..... 10, 91, 92  
non-return valve ..... 14, 17, 99

---

**W**

wash-up..... 11, 13  
working window.....see *DISPLAY >> GRAPHIC  
DISPLAY >> WINDOW >> MAIN WINDOW*